

Series 50 & 50BH Pickups

- **Speed Range:** typically 50 RPM min. to 4000 RPM max.
- **Sine wave output**
- **Passive, no external power source required**
- **Compact 3/8" & 5/8" diameter packages**
- **Rugged, mill-duty construction**

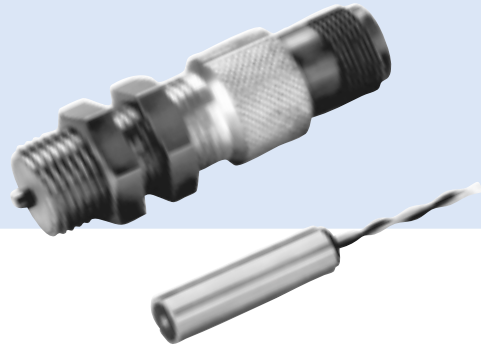

SENSORS AND PICKUPS

APPLICATION/INDUSTRY

Typically used in conjunction with a variety of instruments for indicating or controlling speed, flow rate, etc.

DESCRIPTION

These variable reluctance, magnetic sensors are the simplest, most economical form of speed sensing. Motion and speed are sensed without mechanical couplings, bearings, linkages or an external power source. A sinewave alternating voltage signal is generated synchronously in the presence of gear teeth made of carbon steel, magnetic stainless steel, or iron (ferrous metal). Output voltage and frequency start at zero with zero target speed, and both increase with the increasing speed of a passing target.

FEATURES AND BENEFITS

Advantages of magnetic pickups include

- Ability to generate a wide range of error-free speed signals
- Moderately priced
- Reliable operation with little protection required
- Good for wet, dirty, high temperature environments
- Many industrial, military, and commercial applications.

SPECIFICATIONS

STANDARD OPERATING CHARACTERISTICS

Operating Temperature: 0° to 170°F

Recommended Gap: .005 inch

Output: Greater than .5 volt peak (2K ohm load) above 3 in./sec.

Cable Length: Maximum recommended cable length is 100 feet, but can be extended to 300 feet with minimum speeds above 300 RPM. Line amplifiers are available for longer line lengths. Consult factory.

DC Resistance: 500 to 650 ohms

APPROXIMATE DIMENSIONS (IN INCHES)

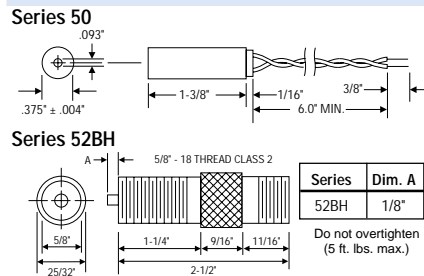

Recommended Dynapar brand Gears

Gear	Dia.	Bore	Pitch	PPR	50	52BH
16002070081	3-1/10"	3/8"	20	60	X	
16002070083	3-7/8"	1/2"	16	60	X	
16002070216	5-1/2"	1-1/8"	11	60	X	X
16002070217	5-1/2"	1-3/8"	11	60	X	X
16002070218	5-1/2"	1-5/8"	11	60	X	X
16002600314	5-1/2"	1-7/8"	11	60	X	X
16002600315	5-1/2"	2"	11	60	X	X
16002600316	5-1/2"	2-1/8"	11	60	X	X
16002600317	5-1/2"	2-1/4"	11	60	X	X
16002600318	5-1/2"	2-3/8"	11	60	X	X
16002600319	5-1/2"	2-1/2"	11	60	X	X
16002600320	5-1/2"	2-7/8"	11	60	X	X

Application Guidelines

Characteristics required for proper selection and application of variable reluctance sensors include:

1. Target speeds of interest must be greater than approximately 180 in./min. (60 tooth gear operation: 50 to 4000 RPM), and will generate operational voltage levels typically 0.5 to 2 volts peak-to-peak.
2. Minimum target length and width dimensions should be greater than and centered on the diameter of the pole tip.

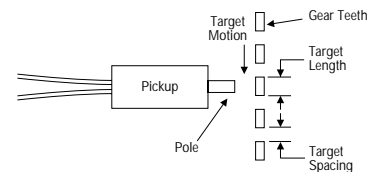

3. Target spacing must be at least three times the length of the target.
4. The gap between the target and the tip of the pickups pole should be as small as possible (output voltage is optimized at a gap of 0.005").

For more application information, refer to the "Fundamentals for Applying Magnetic Pickups" discussion in the Application Reference section of this catalog.

ELECTRICAL CONNECTIONS

Function	Series 50 Wire Color Code	Series 52BH Pin No.	Dyn.#14002030010* Cable Acc'y Color Code
Signal Out	WHT	A	RED
Common	BLK	B	BLK

Note: Wire with 2-conductor shielded cable, such as Belden 8737 should be insulated at sensor and grounded at the instrument.

*This is a cable assembly described in the Encoder Accessories section of this catalog. (A mating connector is also available.) Color-coding information is provided here for reference.

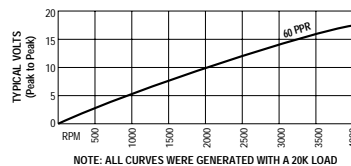

NOTE: ALL CURVES WERE GENERATED WITH A 20K LOAD
Typical Output Voltages vs. RPM

Typical Installation Methods (For All Dynapar Pickups)

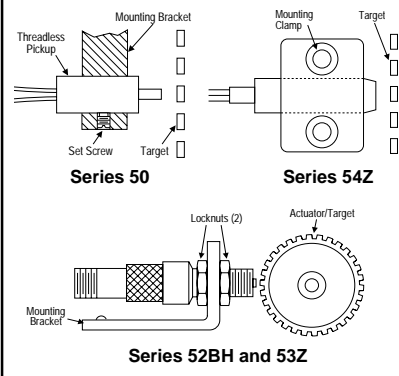

Ordering Information

Output Waveform	Termination	Tip Length	Model No
	6" leads Pin connector	— 1/8"	50 52BH

Note: For slower speed applications, refer to Series 53Z magneto-resistive pickups.