

Encoder Installation Manual

Document No.: 702947-0001
 Revision Level: A
 July 13, 2012

NorthStar[™] brand SERIES RIMFV Frequency to DC Converter

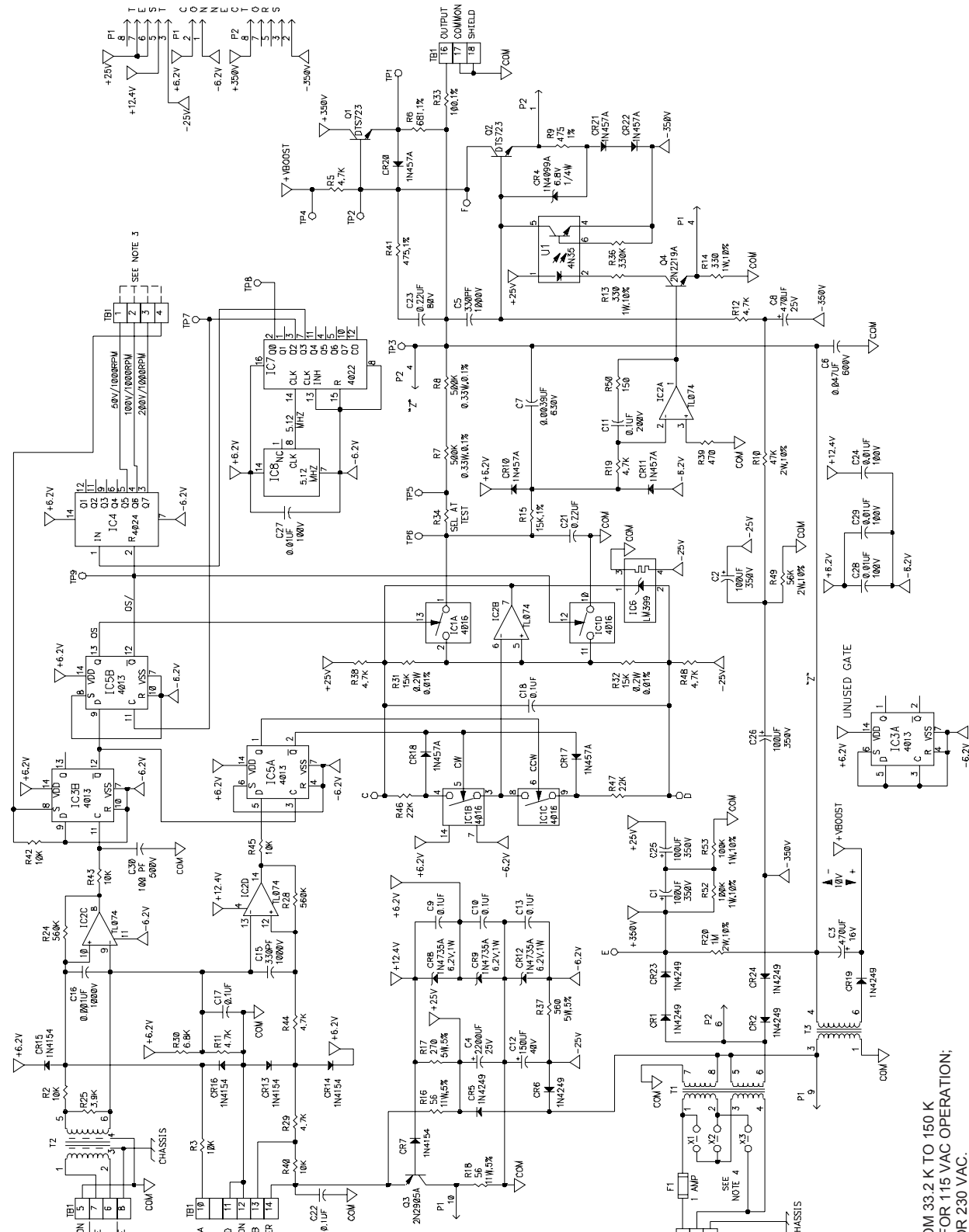

- 5 - R34 SELECT FROM 33.2 K TO 150 K
 - 4 - USE X1 AND X3 FOR 115 VAC OPERATION;
USE X2 ONLY FOR 230 VAC.
 - 3 - JUMPER TB1-4 TO TB1-1, -2, OR -3 TO ACHIEVE
DESIRED GAIN.
 - 2 - CAPACITOR VALUES ARE IN MICROFARADS AND ARE 50 V
 - 1 - RESISTOR VALUES ARE IN OHMS AND ARE 1/2 W, 10%
- NOTES: UNLESS OTHERWISE SPECIFIED

DESCRIPTION

The RIMFV is a high voltage frequency to DC converter. The unit is designed for use in conjunction with encoders and pulse generators as a direct replacement of analog tachometer generators such as the G.E. types BC46 and BC42, A.E.I. type BD2510 and Reliance type RE210 in existing drive control systems. The unit precisely converts an input frequency representing the process variable (speed) to an accurate, stable, analog DC voltage for control use.

RIMFV Output with NorthStar RIM Tach Digital Encoders
 Two styles of encoders are recommended for use with the RIMFV. Recommended NorthStar encoders (RIM6200 & RIM8500) permit direct replacement of analog tachometers. RIM6200 may be foot mounted. Encoder selection depends on the output required from the RIMFV and types of service required.

NOTE

RIMFV can supply 100 mA max. current to the encoder.

For example:

STYLE 1: Two Phase Zero Speed (Example Encoder: RIM6200, RIM8500).

For bidirectional, zero speed applications. The RIMFV output voltage reverses when drive runs backwards. Use with nearly any drive.

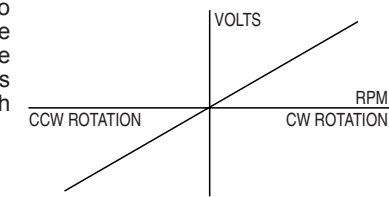

STYLE 2: Single Phase Zero Speed (Example: RIM6200, RIM8500)

For unidirectional, zero speed applications. The RIMFV output voltage does not reverse when drive runs backwards. 3 wire interconnection to RIMFV. Use with non-regenerative drives or drives where tach voltage does not determine rotation direction.

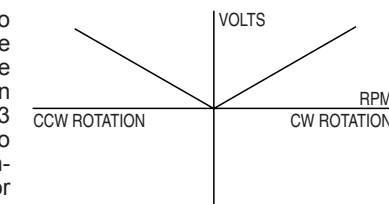

NOTE

When using a style 2 encoder, the output polarity can be reversed by a jumper on the RIMFV.

When using a style 1, the output polarity may be reversed by reversing the ØA - ØB inputs.

The RIMFV provides a full scale output of ±300 VDC at up to 3 milliamperes of current. The unit can be programmed for 50, 100, or 200 volts per 1000 RPM by a jumper on TB1. The RIMFV provides a high conversion speed for a very stable linear output. Because only the encoder or pulse generator is mounted directly to the machine, the RIMFV is to be located in a separate equipment enclosure, isolated from vibration and other adverse environmental effects. This will provide reliable operation and extended service life.

INSTALLATION

Install the associated rotary pulse generator in accordance with the Encoder Installation Instructions and specific instructions for the encoder used.

The RIMFV should be mounted in an equipment enclosure. When mounting on a vertical panel, position the RIMFV mounting face with the longer dimension vertical to minimize tension loading on the upper mounting hardware.

Do not mount RIMFV near sources of large electrical noise such as contactors, motor starters, etc. The RIMFV should be located in an environment where the ambient temperature does not exceed 140°F.

REPAIR OR REPLACEMENT

To minimize costly downtime, it is recommended that a spare RIMFV be kept on hand. In the event of a suspected malfunction, the unit can be quickly removed and the spare installed with no setup changes required.

If the unit is to be sent back to the factory, it is suggested that the user notify NorthStar's Returns Department and supply them with the model and part number of the unit. A brief description of the suspected fault is also helpful.

PREPARATION FOR USE

STEP 1: GAIN PROGRAMMING

CAUTION

Always confirm that a jumper exists in one of these configurations before placing the unit into operation.

Select proper jumper on TB1 as shown to achieve 50, 100, or 200 V/1000 RPM.

NOTE

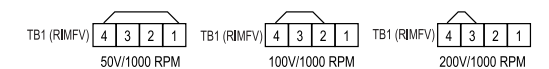

Unit is shipped with jumper set for 200 V/1000 RPM.

STEP 2: INPUT CONNECTIONS

Connect the encoder or pulse generator to the input of the RIMFV per the appropriate style interconnection diagram below. Refer to the instruction sheet for the specific encoder to get the correct connections for that model and output connector option. Note: RIMFV TB1 terminal numbering does not reflect the physical locations of terminal points.

STYLE 1: Encoders with two phase (A,B) type outputs.

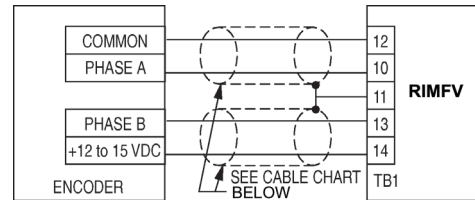

Typical for encoders such as NorthStar RIM 6200.

The RIMFV input is single ended. When using NorthStar encoders with differential outputs, follow the examples for single ended applications and leave the complementary outputs un-terminated. The above connections will result in positive output of the RIMFV for clockwise rotation as viewed from the anti-drive end of the encoder. Counter clockwise rotation will result in negative output. To reverse polarity, reverse phase A and phase B connections at TB1 (RIMFV).

STYLE 2: Encoders with single phase zero speed outputs.

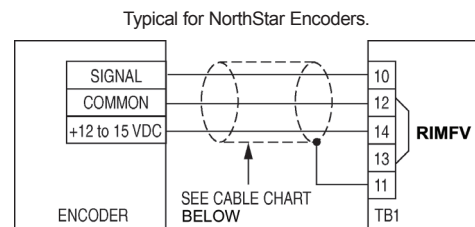

Typical for NorthStar Encoders.

The above connections will result in positive output of the RIMFV for both clockwise and counter clockwise rotation of the encoder. For negative output omit the jumper between RIMFV terminals 12 and 13 on TB1.

STEP 3: OUTPUT CONNECTIONS

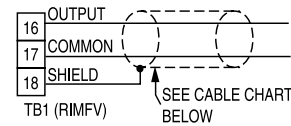

Output COMMON is isolated from earth ground.

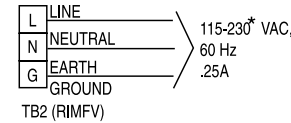

STEP 4: AC POWER CONNECTIONS

*For 230 VAC input power, remove cover and connect jumpers as shown on printed circuit board silkscreen.

CABLE SELECTION CHART			
Number of Conductors	Wire Gauge	Maximum Run	Belden P/N or equivalent
2 (1-shielded pair)*	16	1,000 ft.	8719
3 (shielded)*	16	1,000 ft.	8618
4 (2-shielded pairs)	20	400 ft.	9402
3 (shielded)	20	400 ft.	8772
4 (2-shielded pairs)	22	250 ft.	8723
3 (shielded)	22	250 ft.	8771

SPECIFICATIONS

All specifications are determined using a 240 PPR Encoder.

INPUT:

- Power:** 115 VAC $\pm 15\%$, approx. 0.25 A
- Transformer isolated reluctance input TB1 (6) and (7)**
 - Impedance: 600 ohms $\pm 20\%$ from 100 to 10,000Hz; 40 ohms DC resistance.
 - Input Speed: 0 to 3000 RPM at 50 V/1000 RPM
0 to 3000 RPM at 100 V/1000 RPM
0 to 1500 RPM at 200 V/1000 RPM
 - Input Waveform: 0.5 to 5.0 V Sine Wave
- Zero Speed Input:**
 - Impedance: 10 K ohms
 - Input Speed: Same as above
 - Input Waveform: 5.0 to 15.0 volts square wave.
 - Encoder Power: 13.5 VDC @ 100 mA

SIGNAL OUTPUT:

- Full Scale Voltage:**
 - (Bidirectional) 300 ± 3 VDC
 - (Unidirectional) 300 ± 3 VDC
 - 0 VDC at 0 Hz.
- Programmable Output Gains:** 50, 100, and 200 volts per 1000 RPM of encoder with 240 pulses per revolution (PPR).

3. Signal Output Polarity:

- (Bidirectional): Determined by phase order from encoder; i.e., ØA leads ØB for (+) output.
- (Unidirectional): Determined by jumper on TB1; i.e., jumper on terminals (12) and (13) of TB1 is (+) output. Remove jumper for (-) output.

OUTPUT LINEARITY: Maximum 0.002% of full scale.

- Temperature Drift:** Maximum $\pm 0.05\%$ of full scale from 32 to 140°F
- Stability:** Maximum $\pm 0.02\%$ of full scale over 30 days

OUTPUT RIPPLE: Volts peak-to-peak depends upon the input speed. Open loop ripple at 100 V/1000 RPM is .9 VRMS at 25 RPM, 0.15 VRMS at 250 RPM, and 0.1 VRMS at 2500 RPM. This is significantly lower than conventional brush type generators above 25 RPM. Below 25 RPM the ripple amplitude is comparable to DC generators but has less effect on speed because the ripple frequently is higher.

RISE TIME: 0.01 seconds for a step change in frequency. (Time to reach 90% of final value.)

LOAD IMPEDANCE: 100 K ohms (minimum) for full scale 300 VDC output.

LOAD CURRENT: 3mA output current maximum.

DIMENSIONS

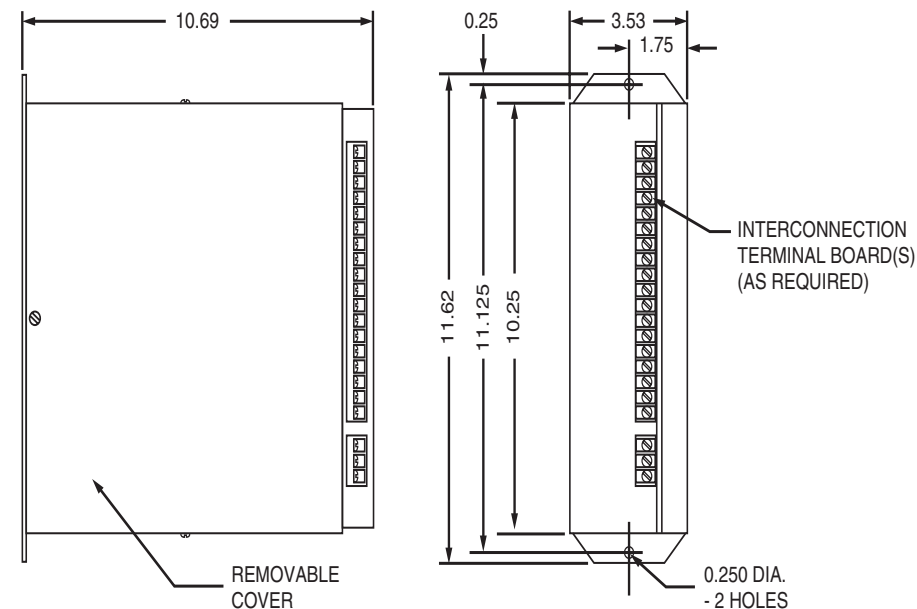

NOTE: NorthStar standard warranty applies. Copies available upon request. Specifications subject to change without notice.