

FRAMELESS SERIES

Harowe™ brand

Heavy Duty Brushless Resolvers

Key Features

- Wide Range of Sizes from 10 to 55
- Multi-Speed Available
- Up to 200°C Temperature Range
- Radiation-Hardened Models Available



SPECIFICATIONS

Model*	Typical Thickness in (mm)	Minimum OD in (mm)	Maximum ID in (mm)
10BRCX	.65 (16.5)	1.05 (26.5)	.237 (6.0)
15BRCX	1.00 (25.4)	1.45 (36.8)	.472 (12.0)
21BRCX	1.25 (31.8)	2.06 (52.4)	.8007 (20.34)
31BRCX	1.25 (31.8)	3.05 (77.5)	1.5763 (40.04)
55BRCX	1.25 (31.8)	5.50 (139.7)	3.6515 (92.75)

*Available as transmitter and control transformer types.

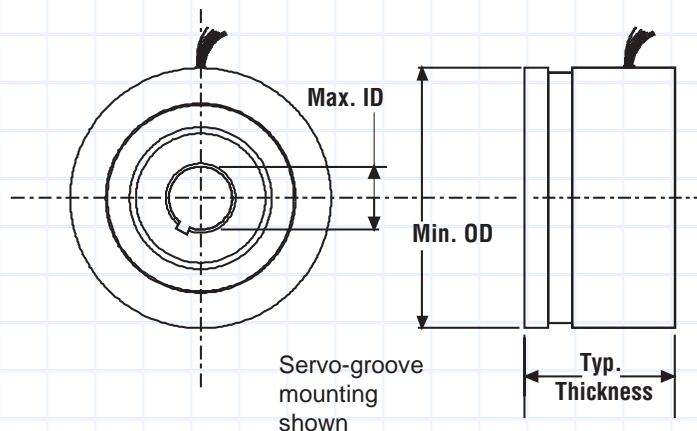



Worldwide Brands: NorthStar™ • Acuro™ • Dynapar™ • Hengstler™ • Harowe™
Headquarters: 1675 Delany Road • Gurnee, IL 60031-1282 • USA • Phone: 1.847.662.2666 • Fax: 1.847.662.6633

Satellite Locations:

- **North America:** North Carolina, South Carolina, Connecticut, Massachusetts, New York, Canada, British Virgin Islands
- **West Indies:** St. Kitts • **Europe:** United Kingdom, Italy, France, Germany, Spain, Slovakia
- **South America:** Brazil • **Asia:** China, Japan, Korea, Singapore

Customer Service:

Tel.: +1.800.873.8731
Fax: +1.847.662.4150
custserv@dynapar.com

Technical Support

Tel.: +1.800.234.8731
Fax: +1.847.782.5277
dynapar.techsupport@dynapar.com

European Sales Representative

Hengstler GmbH
Uhlandstrasse 49, 78554 Aldingen
Germany
www.hengstler.de