

## for AC Synchronous & BLDC Motors



### GENERAL INFORMATION

- Compact hollowshaft motor encoder, ideal for BLDC, DC servo and Stepper feedback
- Incremental + commutation
- Phased Array Technology
- Frequency response to 500kHz
- Standard Operating temperature 0...+120°C
- Outside diameter 50mm
- Cable plug-in radial/axial

The type HC20 encoder provides high performance, cost effective feedback for stepper and servo motor controls. A compliant tether allows easy mounting with high tolerance to motor shaft movement and 20 degrees of adjustment to align the signal outputs to the shaft position.

A superior optical configuration allows for generous internal component clearance eliminating potential damage at high ambient operating temperatures. High temperature rated grease is standard for extended bearing life. No special tools are required for installation.

### NUMBER OF PULSES

500,512,1000,1024,2000,2048,2500;  
optional additional 4,6 or 8 pole commutation signals

### TECHNICAL DATA mechanical

Shaft	taper shaft,blind vertical shaft or hollow shaft
Shaft diameter	6,8,9 mm
Shaft tolerance	nominal taper 2.8624°, +0.2289...-0.000
Axial endplay of mating shaft	±0.8mm
Radial runout of mating shaft	±0.2mm max.(includes shaft perpendicularity )
Diemension	
Outside diameter	50mm(with cover)
Depth	36mm
Max.speed	(Frequency / ppr)×60 or 12 000 min <sup>-1</sup> ,whichever is less
Protection class	IP51(cable needs to be oriented downwards)
Operating temperature	0...+120°C
Storage temperature	-40...+120°C
Shock resistance	1000 m/s <sup>2</sup> (6 ms)
Vibration resistance	25 m/s <sup>2</sup> (5...2 000 Hz)
Material	
Bearing housing	aluminum
Cover	aluminum
Shaft Brass	699477-0001
Weight	120g typ.

## for AC Synchronous &amp; BLDC Motors

 TECHNICAL DATA  
 electrical

Supply voltage	DC 5V $\pm$ 10% (SELV)
Max.current w/o load	Max. 150mA (incremental) Max. 175mA (incremental + commutation)
Incremental signals	A,B
Resolution	Max. 2500 ppr (see ordering information)
Accuracy	40 arc-sec.max.edge to any adge
Phasing A to B	A leads B by 90°ccw ( view on mounting shaft)
Phasing tolerance A to B	$\pm$ 45°electrical
Max.output frequency	250 kHz up to 1 024 ppr 500 kHz > 1024 ppr
Signal level	NPN O.C. Differential Line Driver(RS 422)
Output current	RS422 $\pm$ 40 mA (26LS31) NPN O.C.- 16mA (2k $\Omega$ int. pull up)
Commutation	U,V,W
Signal shape	trapezoid commutation
Phasing	U leads V leads W by 120°
Tolerance N to U	$\pm$ 1°mech.index pulse center to U channel edge (see signal diagram)
Connection	axial or raidal cable available
Reference signal	Z
Index pulse width	90° (gated A and gated B high)

## CONNECTION DIAGRAM

Pin	Signal	Color
1	V <sub>CC</sub>	Red
2	U	Brown
3	GND	Black
4	V	Gray
5	A	Blue
6	W	White
7	$\bar{A}$	Blue/Black
8	N.C.	
9	B	Green
10	$\bar{U}$	Brown/Black
11	$\bar{B}$	Green/Black
12	$\bar{V}$	Gray/Black
13	Z	Violet
14	$\bar{W}$	White/Black
15	$\bar{Z}$	Violet/Black
16	N.C.	

## SIGNAL DIAGRAM

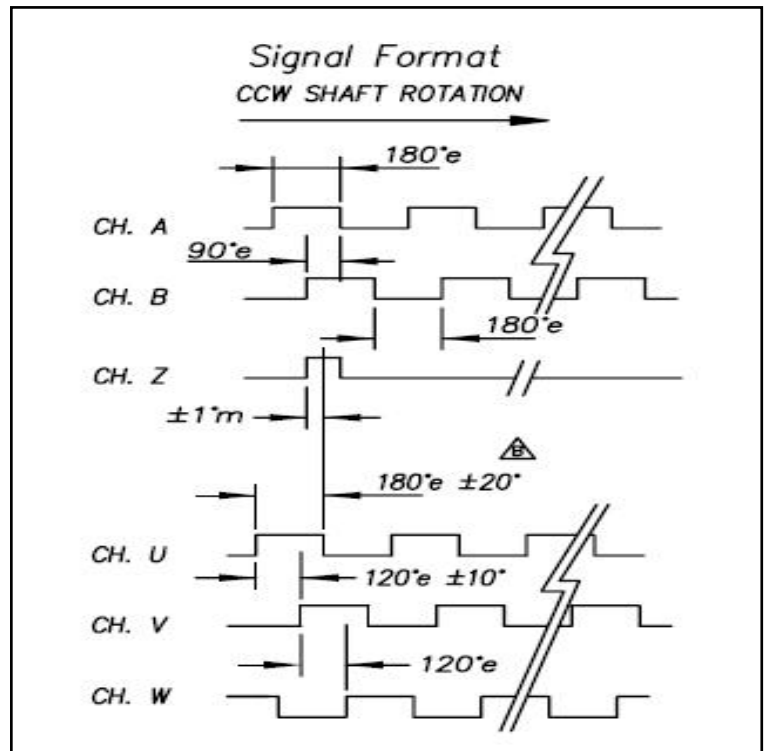

for AC Synchronous & BLDC Motors

DEMENSINAL DRAWINGS

Blind vertical shaft

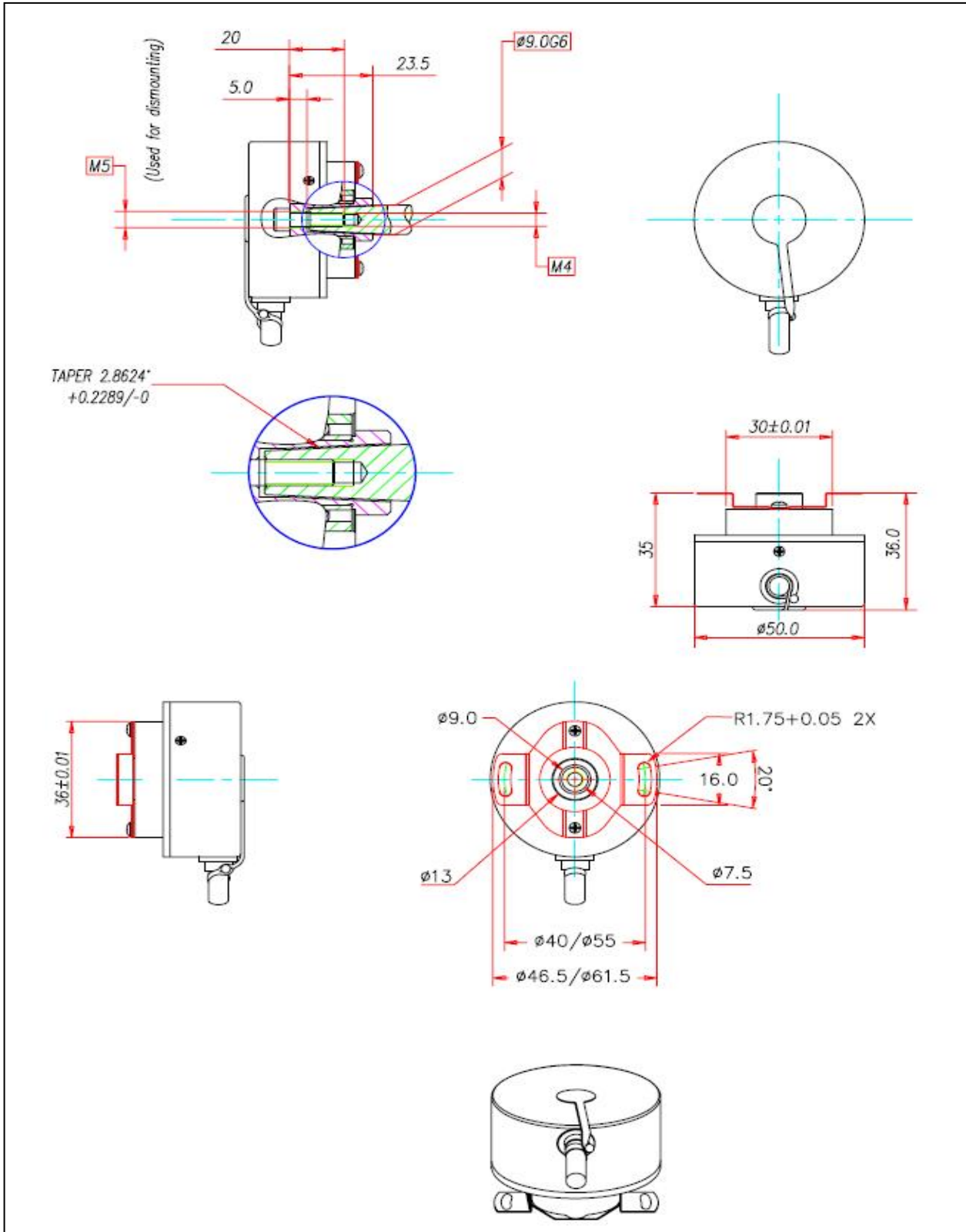

for AC Synchronous & BLDC Motors

Hollow shaft

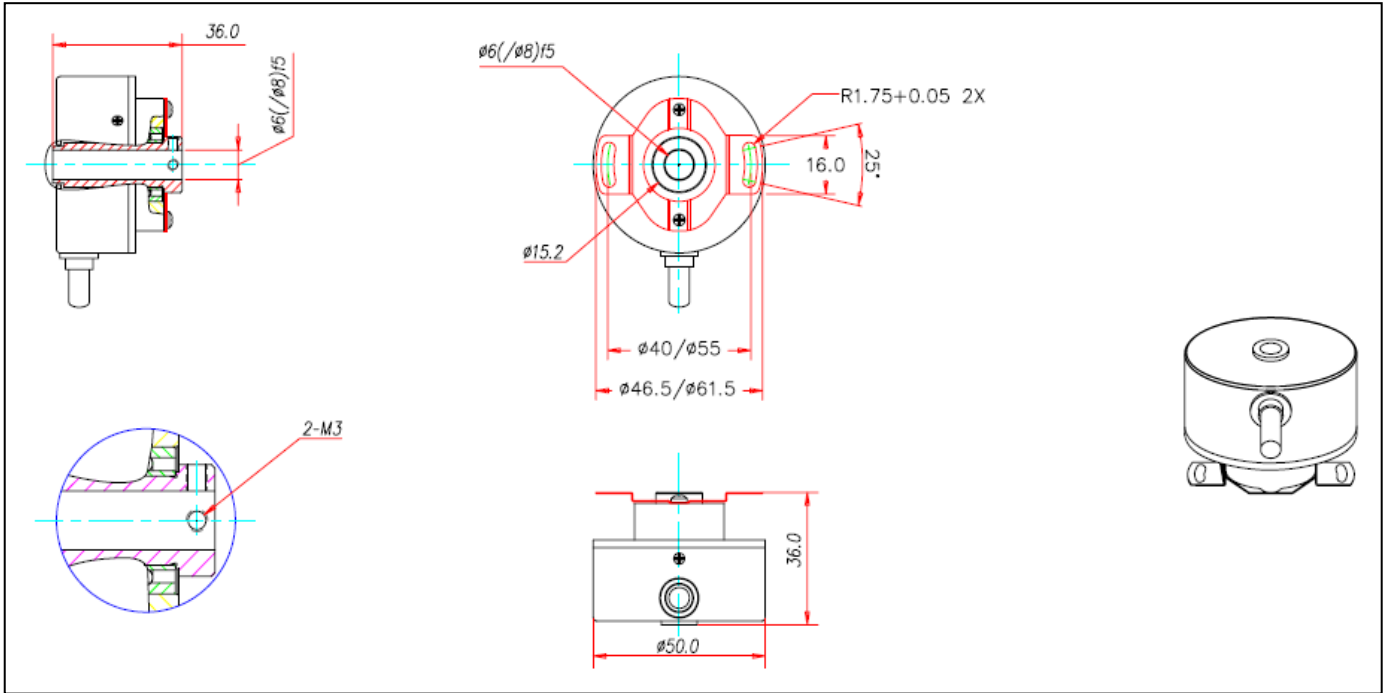

MOUNTING DRAWINGS (inc.  $\phi 40\text{mm}$  and  $\phi 55\text{mm}$ )

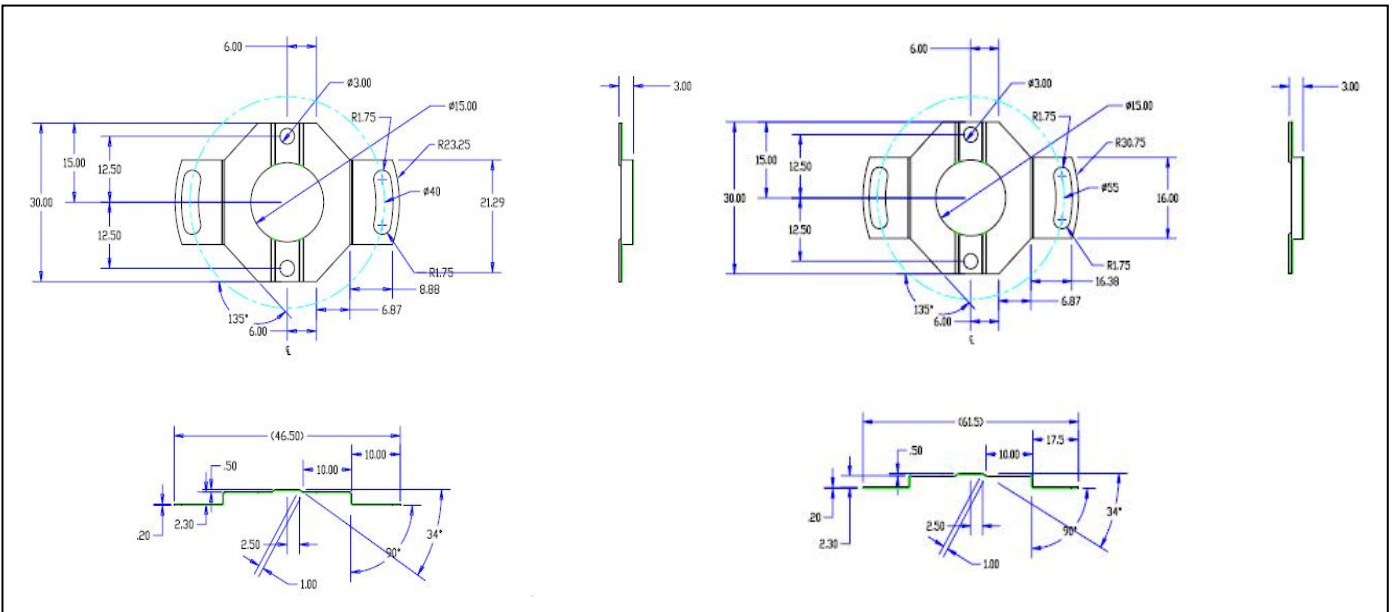

for AC Synchronous & BLDC Motors

ORDERING INFORMATION

Type	Pulses ppr incremental <sup>2</sup>	Poles commutation <sup>2</sup>	Mounting	Electrical <sup>1</sup>	shaft	Connection
<input type="checkbox"/>	<input type="checkbox"/> / <input type="checkbox"/>	<input type="checkbox"/> - <input type="checkbox"/>	<input type="checkbox"/>	<input type="checkbox"/>	<input type="checkbox"/>	<input type="checkbox"/>
HC20	0500	0 without	tether	<b>incremental only,</b>	0 Taper shaft(Ø9,1:10)	Axial plug
	0512	4 4 pole	0 without	<b>&lt;=2 048/0 (ppr/poles)</b>	1 Blind vertical shaft Ø6	1 1 Ft. cable
	1000	6 6 pole	tether	0 U <sub>inc</sub> =DC 5V; output <sub>inc</sub> =NPN-O.C.	2 Blind vertical shaft Ø8	2 2 Ft. cable
	1024	8 8 pole	1 1.575"	<b>incremental only</b>	3 Hollow shaft Ø6	3 3 Ft. cable
	2000		(40mm) TK	<b>without commutation</b>	4 Hollow shaft Ø8	4 4 Ft. cable
	2048		2 2.166"	3 U <sub>inc</sub> =DC 5V; output <sub>inc</sub> =RS 422		5 5 Ft. cable
	2500		(55mm) TK	<b>incremental plus</b>		6 6 Ft. cable
			<b>commutation signals</b>		7 7 Ft. cable	
			6 U <sub>inc</sub> =DC 5V; output <sub>inc</sub> =RS 422		8 8 Ft. cable	
			U <sub>com</sub> =DC 5V; output <sub>com</sub> =NPN-O.C.		Radial plug	
			9 U <sub>inc</sub> =DC 5V; output <sub>inc</sub> =RS 422		A 1 Ft. cable	
			U <sub>com</sub> =DC 5V; output <sub>com</sub> =RS 422		B 2 Ft. cable	
					C 3 Ft. cable	
					D 4 Ft. cable	
					E 5 Ft. cable	
					F 6 Ft. cable	
					G 7 Ft. cable	
					H 8 Ft. cable	

<sup>1</sup> U<sub>inc</sub>:Supply voltage incremental,  
U<sub>com</sub>:Supply voltage commutation (only if commutation is selected)

<sup>2</sup> allowed combinations see available combinations (pulses/poles)

Available combinations (pulses/poles)

Pulse ppr	Number of poles			
	0	4	6	8
0500	x	x	x	x
0512				x
1000	x	x	x	x
1024	x	x	x	x
2000	x	x	x	x
2048	x	x	x	x
2500	x	x	x	x