

NEW

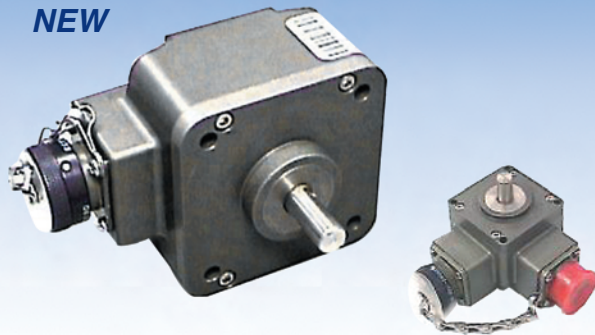

Series HD25

- **Single or Dual output**
- **Optional high current line driver**
- **ATEX Certification available for Intrinsically Safe application**
- **High Resolution Unbreakable Disk**
- **Industrial Duty Connector**
- **NEMA 4X / IP67 Rated**
- **Nickel or Stainless Steel Housing available**
- **Two Year Warranty**

Harsh-Duty Optical Encoder

DESCRIPTION

The HD25 Harsh-Duty Optical Encoder is a compact heavy-duty encoder designed to exceed IP66/IP67 and NEMA 6 enclosure requirements. It is also available in stainless steel that exceeds NEMA 4X and NEMA 6P requirements and is ideal for stringent wash down environments, including those where high pressure steam or caustic chemicals are needed to meet regulatory requirements.

The HD25 features 100 lb Axial and Radial Bearings, -40° to +100°C temperature range and unique labyrinth double-sealed housing, and optional dual “redundant” outputs and is covered by a two-year warranty (one year for bearings). NorthStar’s traditional quality, reliability and value are built-in to every HD25 encoder.

Also available in this series, is an Intrinsically Safe version certified to ATEX EEx ia IIB T4 when used with the appropriate IS Barrier. Accessory barriers can be supplied with the encoder.

APPLICATIONS:

The HD25 Harsh-Duty Optical Encoder is ideal for machine applications with corrosive environments that demand heavy washdown protection. This compact, special-duty encoder is designed to exceed IP66/IP67 and NEMA 6 enclosure requirements with a PPR range through 5000. ATEX certification is also available for intrinsically safe applications.

- **Converting Machinery**
- **Material Handling**
- **Packaging Equipment**
- **Pickling Equipment**
- **Processing Equipment**

INDUSTRIES

Chemical, Food & Beverage, Oil & Gas, Paper, Steel and any other where a precise encoder is needed to operate in harsh environments.

FEATURES/BENEFITS

Mechanical and Environmental

- **Unbreakable code disk**
- **Flexible mounting**
- **Heavy duty shaft seals**
- **Sealed connector**

Electrical

- **Cast housing maximizes noise immunity and durability**

Harsh-Duty Optical Encoder

Series HD25

Harsh-Duty Optical Encoder... Meets Stringent Washdown Requirements

SPECIFICATIONS*

STANDARD OPERATING CHARACTERISTICS

Code: Incremental
Resolution: 1 to 5000 PPR (pulses/revolution)
Format: Two channel quadrature (AB) with optional Index (Z), and complementary outputs
Phase Sense: A leads B for CCW shaft rotation viewing the shaft clamp end of the encoder
Quadrature Phasing: For resolutions to 625PPR: 90° ± 15° electrical; For resolutions over 625 PPR: 90° ± 30° electrical
Symmetry:
 For resolutions to 1024PPR: 180° ± 18° electrical
 For resolutions over 1024PPR: 180° ± 25° electrical
Waveforms: Squarewave with rise and fall times less than 1 microsecond into a load capacitance of 1000 pf

ELECTRICAL

Input Power: 5-26VDC, 5-15VDC dependant on output type. 50 mA max., not including output loads. ATEX: 5VDC, 7-26VDC
Outputs: 2N2222, 4469, ET7272, ET7273
Frequency Response: 125 kHz (data & index)
Termination: 6, 7, or 10 pin MS Connector; 18" cable exit w/seal
Mating Connector:
 6 pin, style MS3106A-14S-6S (MCN-N4);
 7 pin, style MS3106A-16S-1S (MCN-N5);
 10 pin, style MS3106A-18-1S (MCN-N6)

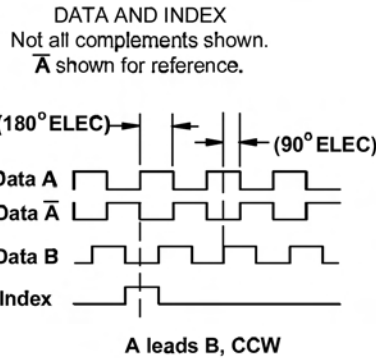

MECHANICAL

Shaft Material: 303 stainless steel (passivated)
Shaft Speed: 6,000 RPM, maximum
Shaft loading: Up to 100 lbs axial and radial
Shaft runout: 0.0005 TIR at midpoint
Starting torque: 2.5 in-oz. maximum (at 25°C)
Bearings: 5200 ZZ double row
Bearing life: 5 x 10⁸ revs at rated shaft Loading, 5 x 10¹¹ revs at 10% of rated shaft loading.(manufacturers' specs)
Housing and cover: Hard Anodized Aluminum. Also available in Electroless Nickel finish and Stainless Steel.
Disc material: Metal or mylar
Weight: 14 ounces, typical

ENVIRONMENTAL

Operating Temperature: -40 to 100°C
Operating Temperature ATEX: -40 to 80°C
Storage temperature: -40 to 100°C
Shock: 50G's for 11msec duration
Vibration: 5 to 2000Hz @ 20 G's
Humidity: 100%
Enclosure Rating: NEMA 4X, NEMA 6, IP66, IP67 (NEMA 6P upon request)
 Note: "MS" type mating connectors and prebuilt cables are rated NEMA 12.

* Specifications are for base models with standard features only unless otherwise noted. Specifications subject to change without notice in accordance with our DBS policy of continuous improvement. All product and brand names are trademarks of their respective owners. All rights reserved.

ELECTRICAL CONNECTIONS

6, 7 & 10 Pin MS Connectors and Cables

Connector & mate/accessory cable assembly pin numbers and wire color information is provided here for reference. HD25 models with direct cable exit carry the color coding as shown in the right hand column.

Encoder Function	Cable # 108594-6 Pin Single Ended		Cable # 108595-7 Pin Single Ended		Cable # 108596-7 Pin Dif Line Drv w/o Idx		Cable # 1400635-10 Pin Dif Line Drv w/ Idx		Cable Exit with Seal
	Pin	Wire Color	Pin	Wire Color	Pin	Wire Color	Pin	Wire Color	Wire Color
Sig. A	E	BRN	A	BRN	A	BRN	A	BRN	GREEN
Sig. B	D	ORG	B	ORG	B	ORG	B	ORG	BLUE
Sig. Z	C	YEL	C	YEL	—	—	C	YEL	ORANGE
Power +V	B	RED	D	RED	D	RED	D	RED	RED
Com	A	BLK	F	BLK	F	BLK	F	BLK	BLACK
Case	—	—	G	GRN	G	GRN	G	GRN	WHITE
N/C	F	—	E	—	—	—	E	—	—
SigA	—	—	—	—	C	BRN/WHT	H	BRN/WHT	VIOLET
SigB	—	—	—	—	E	ORG/WHT	I	ORG/WHT	BROWN
SigZ	—	—	—	—	—	—	J	YEL/WHT	YELLOW

Note: "MS" type mating connectors and prebuilt cables are rated NEMA 12.

Harsh-Duty Optical Encoder... Meets Stringent Washdown Requirements

DIMENSIONS inches [mm]

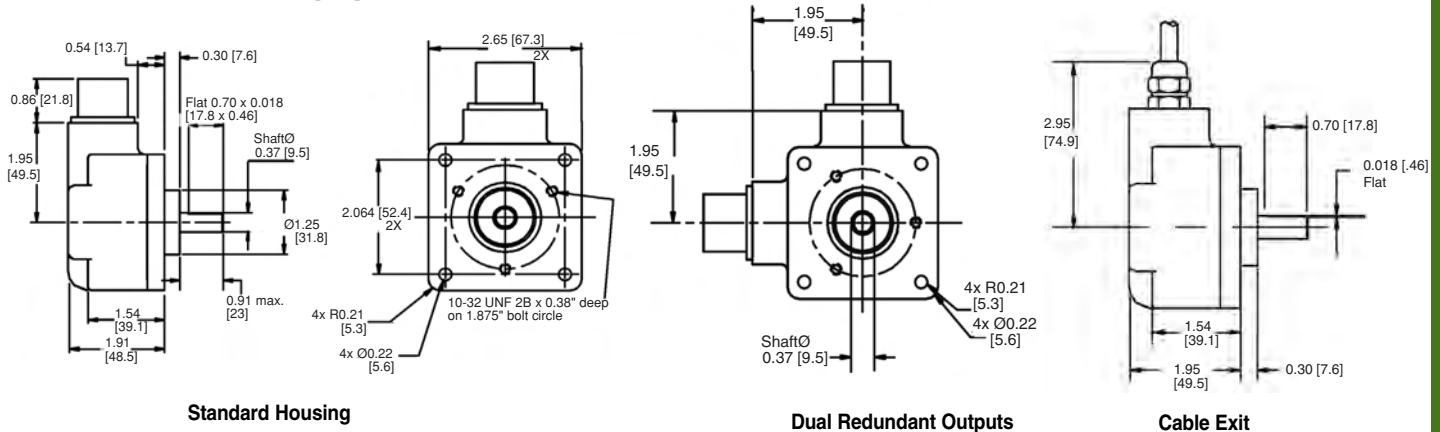

ORDERING INFORMATION

Code 1: Model	Code 2: PPR	Code 3: Shaft	Code 4: Electrical	Code 5: Termination	Code 6: Options
HD25 □	□□□□	□	□	□	□

Ordering Information					
Size 25 Extreme Heavy Duty Encoder 1 Unidirectional 2 Bidirectional 3 Bidirectional with Index	0001 0720 0024 0900 0025 1000 0035 1024 0040 1200 0050 1250 0060 1440 0100 1524 0120 1600 0192 1800 0200 2000 0240 2048 0250 2500 0256 2540 0300 2600 0360 3000 0500 3048 0512 3600 0600 4096 0625 5000	0 3/8" Dia. Shaft with flat 4 10mm Dia. Shaft, with flat	0 5-26V in, 5-26V Open Collector out (7273) 2 5-26V in, 5-26V Push-Pull out F 5-26V in, 5-26V Open Collector out (2222) G 5-26V in, 5-26V Open Collector out with 2.2 kΩ Pullups (2222) available when: Code 1 is 1,2 and Code 5 is 3 through H, or Code 1 is 3 and Code 5 is 5 through H: 3 5-26V in, 5-26V Differential Line Driver out (7272) 4 5-26V in, 5V Differential Line Driver out (7272) 6 5-15V in, 5-15V Differential Line Driver out (4469)	1 6 Pin Connector 3 7 Pin Connector 5 10 Pin Connector D 18" Sealed Cable E 3' Sealed Cable F 6' Sealed Cable G 10' Sealed Cable H 15' Sealed Cable	0 No Options 1 Nickel Finish Housing 2 Stainless Steel Housing 3 Redundant Outputs (Dual Connector Housing). See † NOTE 4 Nickel Finish Housing with Redundant Outputs. See † NOTE 5 Stainless Steel Housing with Redundant Outputs. See † NOTE A Same as "0" w/ ATEX Type 1 B Same as "1" w/ ATEX Type 1 C Same as "2" w/ ATEX Type 1 D Same as "3" w/ ATEX Type 1. See †NOTE E Same as "4" w/ ATEX Type 1. See †NOTE F Same as "5" w/ ATEX Type 1. See †NOTE Available when Code 4 is 0-3, F or G G Same as "0" w/ ATEX Type 2 H Same as "1" w/ ATEX Type 2 I Same as "2" w/ ATEX Type 2 J Same as "3" w/ ATEX Type 2. See †NOTE K Same as "4" w/ ATEX Type 2. See †NOTE L Same as "5" w/ ATEX Type 2. See †NOTE Available when Code 4 is 4 M Same as "0" w/ ATEX Type 3 N Same as "1" w/ ATEX Type 3 O Same as "2" w/ ATEX Type 3 P Same as "3" w/ ATEX Type 3. See †NOTE Q Same as "4" w/ ATEX Type 3. See †NOTE R Same as "5" w/ ATEX Type 3. See †NOTE † NOTE: Simultaneous use of redundant outputs may void ATEX certification. Consult factory for details.

*Note: Available ATEX Certified Options
ATEX Type 1: ATEX Certified; 5V in, 5V out only
ATEX Type 2: ATEX Certified; 7-26V in, 7-26V out
ATEX Type 3: ATEX Certified; 7-26V in, 5V out
 NOTE: ATEX voltages replace those shown in Code 4.

Worldwide Brands:

Dynapar™

Harowe™

Hengstler™

NorthStar™



**A division of
Danaher, a
Fortune 500
company with
offices in 30
countries around
the world.**

More Available. With factories around the world, global sales and applications support, and an expansive network of distributors, we stay close to our customers - shortening lead times and fostering responsiveness. Three-day lead time is standard, with same-day shipments available on many of our products.

More Selection. We have a broad selection of controllers to meet application requirements in a variety of industries. User-configurable, accurate and flexible, with low, mid, or high level performance ranges, our controller products meet your system and budgetary requirements.

More Reliable. Our experience with more than 25,000 customers has taught us to design controllers that are reliable and durable, with quality standards that meet six sigma requirements.

For additional information or a full-line catalog, contact Dynapar Customer Service or visit our web site.

* Specifications are for base models with standard features only unless otherwise noted. Specifications subject to change without notice in accordance with our DBS policy of continuous improvement. All product and brand names are trademarks of their respective owners. All rights reserved.

NorthStar™ brand is a trademark of Dynapar. All rights reserved.

HD25 Data Sheet (03/09) ©2009 Dynapar

Document Number: 702635-0001, Rev-

Headquarters: 1675 Delany Road • Gurnee, IL 60031-1282 • USA
Phone: +1 847.662.2666 • Fax: +1 847.662.6633

Satellite Locations:

North America: North Carolina, South Carolina, Connecticut, Massachusetts, New York, Canada, British Virgin Islands • Europe: United Kingdom, Italy, France, Germany, Spain, Slovakia • Latin America: Brazil • Asia: China, Japan, Korea, Singapore



Factory Automation Worldwide Brands: Dynapar™ • Harowe™ • Hengstler™ • NorthStar™

Customer Service:

Tel.: +1.800.873.8731

Fax: +1.847.662.4150

northstar.custserv@dancon.com

Technical Support

Tel.: +1.800.234.8731

Fax: +1.847.782.5277

northstar.techsupport@dancon.com