

Encoder Installation Manual

NorthStar™ brand

SERIES EN44

Zone 1 “Hazardous Area” Rated Encoder

Document No.: 702828-0001

Revision Level: –

Oct. 25, 2010

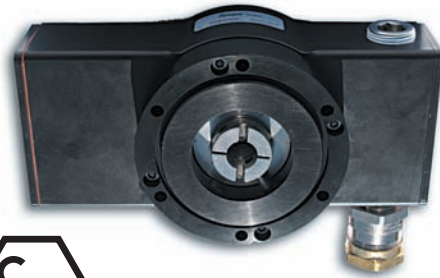

Ex ia mb e IIC T4 Gb
Certification No.
Sira 09ATEX5172X



General

The following instructions are meant to assist in proper installation of the NorthStar Series EN44 Sealed Hubshaft Encoder. The encoder is a harsh-duty speed and position transducer that when mounted to a rotating shaft, produces output pulses that are directly proportional to the shaft speed and direction. The encoder is attached to the motor shaft via a stainless steel flexible coupling that compensates for motor shaft end-play and run-out. The clamp is also electrically isolated from the encoder to ensure motor shaft currents do not ground through the encoder bearings. Due to this specialized coupling, special precautions must be taken during installation as outlined in this manual.

The EN44 was designed specifically for “Hazardous Area” rated applications common in Oilfield operations. Proper operation is dependant upon installation by suitably trained personnel in accordance with the applicable code of practice.

Care should be taken to inspect the shipping container and product for external damage and/or missing parts. If any is found, contact Dynapar immediately as well as the shipping agent.

Tools Required for Installation

Tool	Purpose
Caliper & Dial Indicator Gages	Shaft Checks
1/4" Hex Key Wrench	Shaft Clamp Access Plug
5/32" Ball End Hex Key Wrench	Shaft Collar Clamp and Shaft Clamp Alignment Screw
3/16" Hex Key Wrench	Encoder Mounting Screws
10mm Hex Key Wrench	Stopping Plug
Open End Adjustable Wrench	Cable Gland
7/64" Hex Key Wrench	Terminal Box Cover
1/8" Flat Blade Screwdriver	Terminal Block Wiring
Torque Wrench, 20–75 inch pound range	Tightening Fasteners
Threadlocker, Loctite 242 or equivalent	Retaining Fasteners

Application Environment

The EN44 is uniquely designed with the primary protection technique as Encapsulation.

The encapsulated electronics and increased safety interface allow for use in Zones 1 and 2 with flammable gases and vapors with apparatus groups IIA, IIB & IIC and with temperature classes T1, T2, T3, and T4. The equipment is only certified for use in ambient temperatures in the range –50°C to 100°C.

Compliance with the Essential Health and Safety Requirements has been assured by compliance with the following documents:

EN 60079-0:2006 (General)

IEC 60079-0:2007 (General)

EN 60079-7:2007 (Increased Safety)

EN 60079-18:2004 (Encapsulated)

Before installation or operating in a “Hazardous Area”, the installer must be trained and familiar with hazardous area installation and IEC/EN 60079-14 standards.

Note: Encapsulation techniques are an improvement over “flameproof” 60079-1 Specifications requiring heavy XP metal enclosures to contain a flame. Encapsulation eliminates the air around the electronics preventing ignition and allowing smaller lightweight enclosures to be used in the design.

Table of Contents

Topic	Page
Description & Table of Contents	1
Electrical Installation	2-3
Mechanical Installation	4-5
Specifications	6
SIRA User Instructions	7
SIRA Certification	8-11
Declaration of Conformity	12

ELECTRICAL INSTALLATION

CAUTION: Before installation, ensure power is off and locked out. Failure to do so may damage encoder and/or cause a spark or explosion.

Electrical Installation must be performed by an individual that is trained and familiar with hazardous area installation. Standards that apply are IEC/EN 60079-14 and other applicable wiring codes that apply to the specific location of the installation. Please follow the guidelines for a type “e” Increased Safety Installation. Other cable considerations include flammability, temperature, chemical, etc as applies to the area and environment of installation. If in doubt see the IEC/EN60079-14 standard as applies to Increased Safety installations and local regulations.

Important Wiring Instructions: Use shielded cable with a defined wire gauge per the following table.

* Terminal blocks type ‘e’ certified for the conductor range:

Connectable Conductor Cross Section	
Rigid/Soild Wire mm ² (AWG)	0.14 - 2.5 (26-14)
Flexible/Stranded Wire mm ² (AWG)	0.14 - 1.5 (26-16)

Consider the length of cable and desired drive currents for your application. Consider a 0.5mm² or 20AWG cable as a minimum starting point. You can increase or decrease the wire diameter based on your specific application.

SHIELDING – It is good wiring practice for a shield to be connected to signal-ground at the receiving device only. **Connecting the shield at both ends can cause grounding (loops) problems that degrade system performance and give a path for stray currents to travel.**

CABLE PROTECTION - Run the encoder cable through a dedicated conduit (not shared with other wiring). Use of conduit will protect the cable from physical damage and provide a degree of electrical isolation. If a conduit is not practical use wire trays to protect cable. If there is not a practical way to protect the cable you may consider using armored cable - See section 9 of the IEC/EN60079-14 standard as applies to Increased Safety installations. Do not run the cable in close proximity to other conductors that carry current to heavy loads such as motors, motor starters, contactors etc. This practice can induce electrical transients in the encoder cable, potentially interfering with reliable data transmission.

CAUTION: Unused encoder signal wires must be individually insulated and under no circumstances be in contact with ground, voltage sources, or other signal lines.

Zone 1 Wiring Considerations

CAUTION: The Encoder wiring configuration for the EN series encoder is different than an Intrinsic Safe wiring configuration. No IS barrier, Zener or Galvanic, is required when using the EN series encoder. Barriers may prevent proper operation and/or frequency performance. Damage to the encoder may occur if the encoder output is connected to an IS barrier.

When selecting an encoder, consider the power supply to the encoder and input voltage to your data acquisition, PLC or drive system. Cable length and RPM max will determine which output driver option to select.

The configurations below are examples of protected wiring practices and help to determine the best wiring scheme.

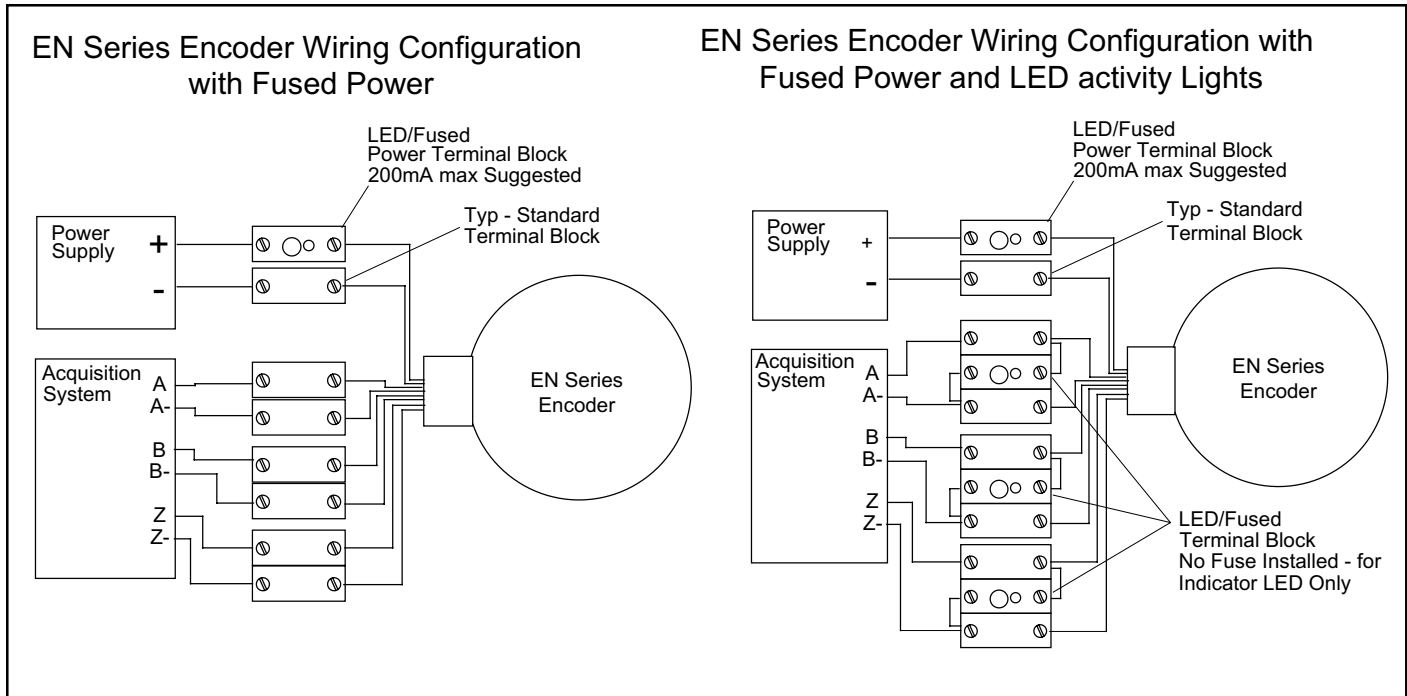

Cable Entry & Gland Selection

This product is supplied with dual 3/4" NPT entry holes for wiring to the terminal block. SPECIAL CONDITIONS FOR SAFE USE (denoted by X in the certificate number) require cable entry to be fitted with an ATEX certified Type "e" cable gland. Any gland certified for use as Type "e" and matching the cable selected and designed to fit a 3/4" NPT can be used.

If ordered from Dynapar with no gland, customer must supply an appropriate gland. If ordered with one of our available glands, proper manufacturers assembly instructions must be followed. Refer to HAWKE assembly instructions included with your product, or locate and reference them on the HAWKE website: www.ehawke.com.

Dynapar Available Glands. (ref. page 6 "Ordering Information" – Code 5)

Code 1: Non-Armored Cable – HAWKE 501/421 A 3/4" NPT S
Assembly Instruction: **A1 307 / Issue M – 11/08**

Code 2: Armored Cable – HAWKE 501/453/UNIV A 3/4" NPT
Assembly Instruction: **A1 300 / Issue M – 11/08**

Signal and Wiring

WAVEFORMS

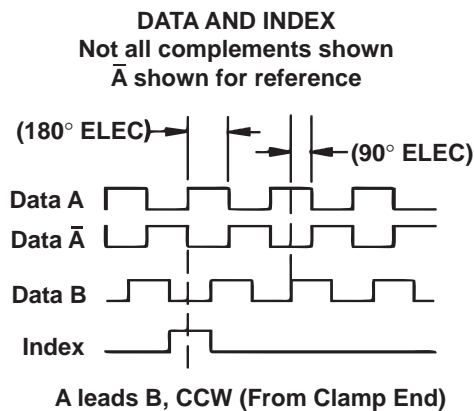

ELECTRICAL CONNECTIONS

Encoder Function	Terminal Box Connection
Sig. A	1
Sig. A̅	2
Sig. B	3
Sig. B̅	4
Sig. Z	5
Sig. Z̅	6
Power +V	7
Com	8

Wiring Procedure

Step 1: Remove terminal box cover. Assemble cable & gland per manufactures instructions.

Step 2: Strip cable jacket back 3 inches. Strip individual leads back 0.35".

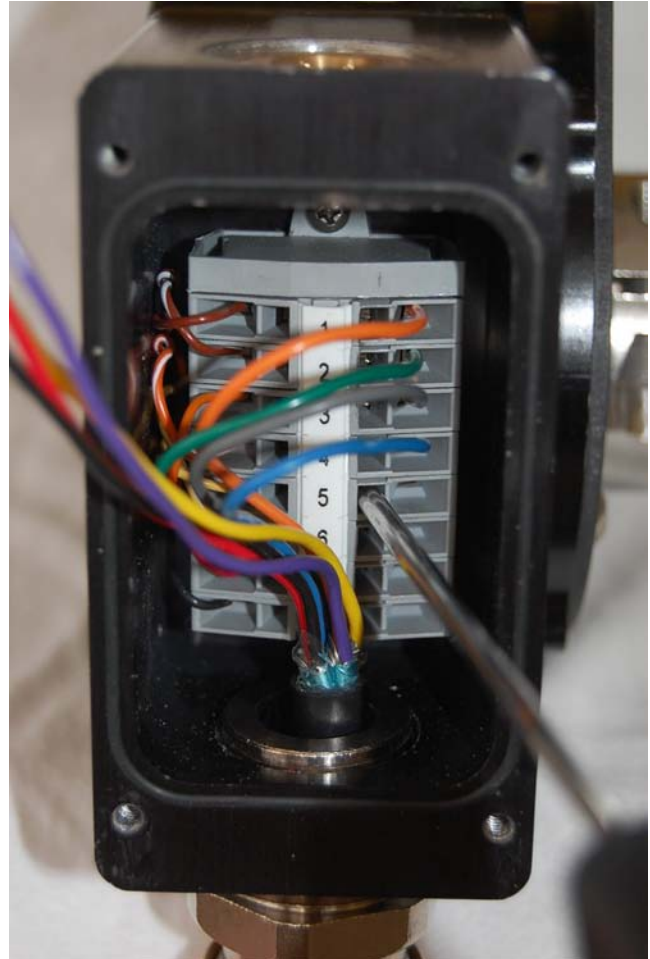

Step 3: Wire to terminal block using pin assignment on this page or on the inside of terminal box cover. Carefully press a 1/8" flat blade screw-driver into the inboard hole to open terminal. Insert wire completely and remove screwdriver.

Step 4: Replace terminal box cover.

MECHANICAL INSTALLATION

CAUTION: Upon initial inspection of the shaft coupling area of the EN44 you will notice a 10-32 screw that extends through the encoder body and into the shaft coupling.

DO NOT remove this Coupling Locating Screw until directed to do so in Step 9 of the Installation Procedure.

Please familiarize yourself with the following as seen in the magnified view drawing below:

1. Shaft Clamp Screw
2. Shaft Clamp Access Plug
3. Flex Coupling Locating Screw
4. Coupling Locating Hole

Note: The encoder can be mounted on shafts of varying lengths (MIN 0.47 in, MAX 0.83 in).

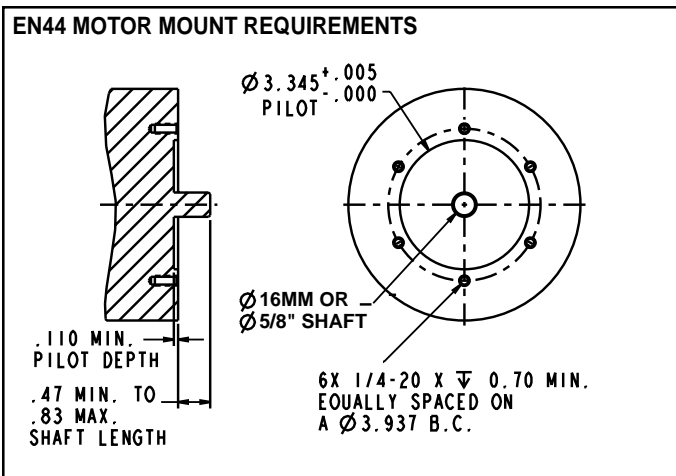

STEP 1: Please reference the below diagram titled "EN 44 Motor Mount Requirements" to ensure that a correct mounting interface is provided for the mechanical installation of this encoder. The EN44 has a 0.110 inch piloted face that is concentric with the Flex Coupling. Be sure to create a concentric pilot with the six 1/4-20 inch threaded holes on customer equipment as shown in the diagram.

STEP 2: Ensure the mounting interface and shaft extension are free of dirt, grease, or any other foreign matter. Check the shaft Total Indicated Run-out (TIR), and ensure that it does not exceed 0.005" TIR.

STEP 3: Using the 1/4" hex key, remove the Shaft Clamp Access Plug from the side of the encoder body.

STEP 4: Place the 5/32" ball end hex key into the access hole and loosen the Shaft Collar Clamp Screw. Place a small amount of threadlocker on the screw threads and re-install it into the Clamp Collar. Re-thread the screw into the clamp loosely. **DO NOT TIGHTEN.** Remove the 5/32" ball end hex key from the access hole.

STEP 5: Place a Lockwasher onto each 1/4-20 x 1" Encoder Mounting Screw (6 required). Apply a small amount of threadlocker to the screw threads.

STEP 6: While observing the proper orientation of the cable exit, slide the encoder straight over the motor shaft extension, and engage the encoder's Flex Coupling. Note again, shaft engagement is MIN 0.47" MAX 0.83".

EN44 COUPLING/CLAMP INSTALLATION

Note: Please refer to this figure when performing Installation Steps 7 – 11.

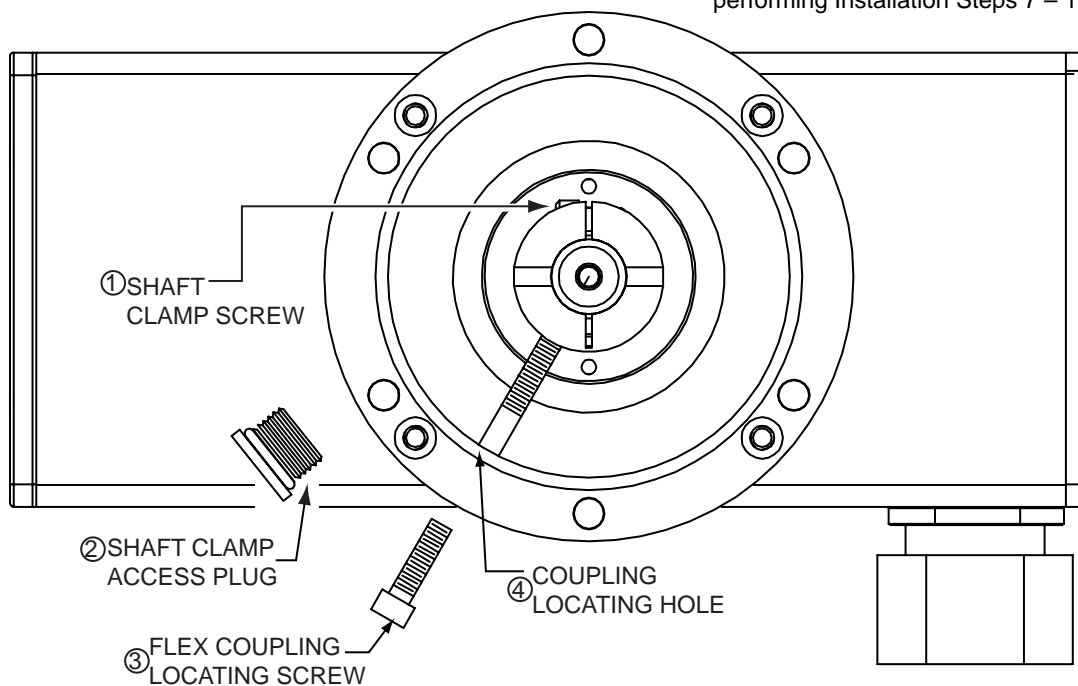

MECHANICAL INSTALLATION

Note: Please refer to ‘EN44 Coupling/Clamp Installation’ figure (previous page) when performing Installation Steps 7 – 11.

STEP 7: Install the six Encoder Mounting Screws using the 3/16” hex key and torque to 75 inch pounds.

STEP 8: Using the 5/32” hex key, tighten the Shaft Clamp Screw. Torque to 36 inch pounds. Remove the 5/32” hex key.

CAUTION: The motor shaft must NOT be rotated until Step 9 (below) is performed, or damage to the encoder flex coupling will result.

STEP 9 Using the 5/32 hex key, completely remove the 10-32 x 1.5” Flex Coupling Location Screw. This screw is no longer needed for installation, instead replace with the shorter 10-32 x 7/8” screw. Obtain the 10-32 x 7/8” SHCS from the hardware kit (this screw has an o-ring under the head). Apply a small amount of threadlocker to the screw threads. Using the 5/32” hex key install the screw into the Coupling Locating Hole and torque to 20 inch pounds. The purpose of this shorter screw is to block the hole while in operation.

STEP 10 Apply a small amount of threadlocker to 1/8” NPT Shaft Clamp Access Plug threads. Using the 1/4 hex key, install the plug and torque to 60 inch pounds.

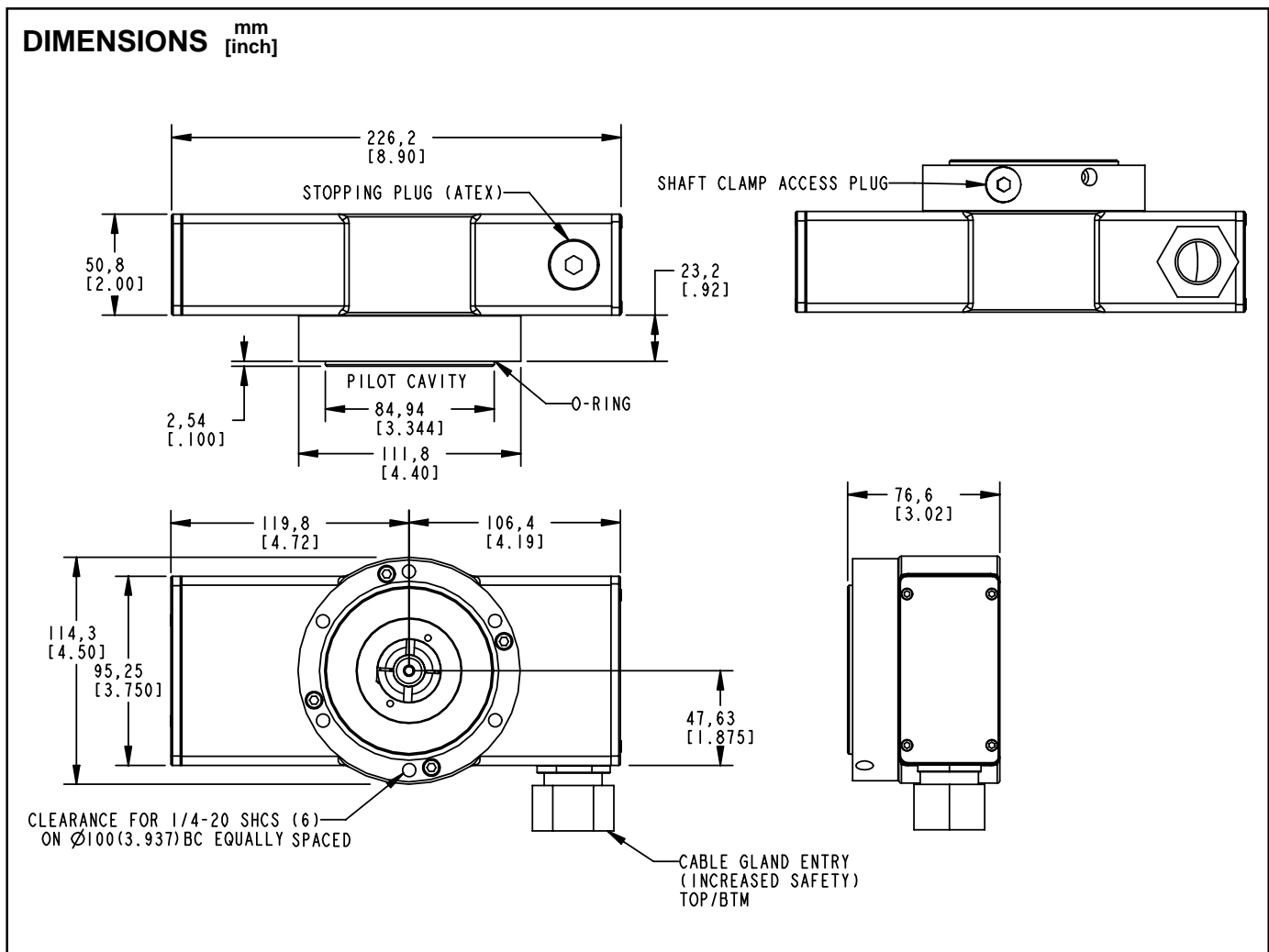

SPECIFICATIONS

STANDARD OPERATING CHARACTERISTICS

Code: Incremental
Resolution: to 2048 PPR (pulses/revolution) See Ordering Information
Format: Two channel quadrature (AB) with optional Index (Z, ungated), and complementary outputs
Index: 180 degrees ±18 degrees (electrical), ungated
Phase Sense: A leads B for CCW shaft rotation viewing the shaft clamp end of the encoder
Quadrature Phasing: 1200 PPR: 90° ± 15° electrical; 2048 PPR: 90° ± 30° electrical
Symmetry: 180° ± 18° electrical
Waveforms: Squarewave with rise and fall times less than 1 microsecond into a load capacitance of 1000 pf

ELECTRICAL

Input Voltage: 5-15VDC, 5-26VDC (see ordering information)
Input Current: 65mA max., not including output loads
Outputs: TC4428 Line Driver
Output Current: (Refer to Ordering Information Table, Code 4: ATEX Output Format)
 Code 4 Option 0 or 2: 125mA max. per channel
 Code 4 Option 1 or 3: 10mA max. per channel @ 100°C; 15mA max. per channel @ 90°C

Frequency Response: 125 kHz (data & index)
Termination: Terminal block - Ex screwless w/spring cage-clamp
Interface: HAWKE type "E" increased safety rated gland for armored and non-armored cables.

HAWKE Part Numbers:

Non-Armored Gland: HAWKE 501/421 A 3/4" NPT S
 (accepts 8.5 - 13mm cable, OD)
Armored Gland: HAWKE 501/453 UNIV A 3/4" NPT
 (accepts 12.5 - 20.5mm cable, OD)

MECHANICAL

Mechanical Interface: Stainless steel shaft clamp
Mating Shaft Length: 0.47" to 0.83" (11.9mm to 28.1mm)
Coupling: 16mm, flexible
Shaft Speed: 6000 RPM, max.
Bearings: 6107
Bearing life: 5 x 10⁸ revs at rated shaft Loading, 5 x 10¹¹ revs at 10% of rated shaft loading. (manufacturers' specs)
Housing Material: Aluminum Alloy, Black Anodized
Disc material: Mylar®
Weight: 6 lb. 6 oz, typical

ENVIRONMENTAL

Operating Temperature: -50 to 100°C. See †Note
Storage temperature: -50 to 100°C. See †Note
Shock: 50G's for 11msec duration
Vibration: 5 to 2000Hz @ 20 G's
Humidity: 100%
Enclosure Rating: IP67

† **Note:** Armored Gland high-temperature specification limited to +80°C. Certification at +100°C pending for Feb 2011

* Specifications subject to change without notice. All product and brand names are trademarks of their respective owners. All rights reserved.
 NorthStar™ brand is a trademark of Dynapar.
 All rights reserved. © 2010 Dynapar
 Mylar® is a registered trademark of Dupont

Models

Ordering Information

To order, complete the model number with code numbers from the table below:

Code 1: Model	Code 2: PPR	Code 3: Bore Size	Code 4: ATEX Output Format	Code 5: Termination
EN44	□□□□	□	□	□
Ordering Information				
EN44 ATEX Zone 1 Hubshaft Encoder	1024 2048	A 16mm	0 Differential AB, 5-15V in, 5-15V out 1 Differential AB, 5-26V in, 5V out 2 Differential ABZ, 5-15V in, 5-15V out 3 Differential ABZ, 5-26V in, 5V out <div style="border: 1px solid black; padding: 2px; width: fit-content; margin-top: 5px;">* See Electrical Specifications for Details</div>	0 No Gland 1 Ex Gland for non-armored cables (8.5 - 13.5mm OD) 2 Ex Gland for armored cables (12.5 - 20.5mm OD) See †Note

† **Note:** Armored Gland high-temperature specification limited to +80°C. Certification at +100°C pending for Feb 2011

SIRA USER INSTRUCTIONS

1. The certification marking is as follows:

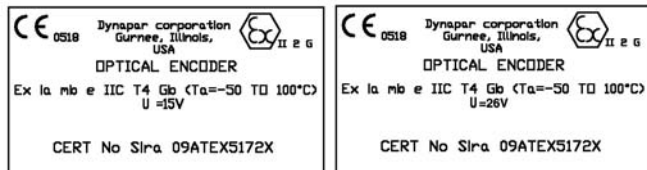

2. The equipment may be used in Zones 1 and 2 with flammable gases and vapours with apparatus groups IIA, IIB & IIC and with temperature classes T1, T2, T3 and T4.

3. The equipment is only certified for use in ambient temperatures in the range -50°C to +100°C and should not be used outside this range.

4. The certificate number has an 'X' suffix, which indicates that the certificate contains one of more special conditions for safe use. Those installing or inspecting the equipment should refer to this section of the certificate.

5. The equipment has not been assessed as a safety-related device (as referred to by Directive 94/9/EC Annex II, clause 1.5).

6. The equipment has not been assessed as a safety-related device (as referred to by Directive 94/9/EC Annex II, clause 1.5).

7. Installation of this equipment shall be carried out by suitably-trained personnel in accordance with the applicable code of practice.

8. Repair of this equipment shall only be carried out by the manufacturer or in accordance with the applicable code of practice.

9. The certification of this equipment relies on the following materials used in its construction:

Enclosure: Case material type - Anodized aluminium.

Other external parts and Shaft material: Aluminium or SST.

Potting Compounds: Silicone Based

Sealing Orings: Silicone type

Shaft seals: Viton

If the equipment is likely to come into contact with aggressive substances, then it is the responsibility of the user to take suitable precautions that prevent it from being adversely affected, thus ensuring that the type of protection is not compromised.

"Aggressive substances" - e.g. acidic liquids or gases that may attack metals, or solvents that may affect polymeric materials.

"Suitable precautions" - e.g. regular checks as part of routine inspections or establishing from the material's data sheet that it is resistant to specific chemicals.

* Temperature ratings - The equipment is only certified for use in an ambient temperature range -50°C to +100°C.

* The encoder is rated at IP54 for certification purposes. In order to achieve this level of protection, appropriate ATEX certified type 'e' Glands or Plugs must be used by the end user. The thread form of the cable entries is 3/4 NPT.

* Terminal blocks type 'e' certified for the conductor range:

Connectable Conductor Cross Section		
Rigid [mm ²] (AWG)	0.14 - 2.5 [26-14]	0.14 - 2.5 [26-14]
Flexible [mm ²] (AWG)	0.14 - 1.5 [26-16]	0.14 - 2.5 [26-16]

MAINTENANCE ISSUES

* Periodic inspections should be made to ensure that there is not excessive play in the encoder shaft due to bearing wear or damage.

Additional documentation provided with each unit:

* Sira Certificate

* Installation, NonBarrier #200872-0001

PREPARATION:

Disconnect power from equipment and encoder cable.

Note: Ensure that pipe-thread tape or equivalent sealer is applied to the conduit entry stopping plug and mating cable gland for proper sealing.

Position the anti-rotation arm at a 90 degree angle (Ideal) to the motor shaft.

This orientation ensures:

* Minimal housing rotation and encoder error caused by relative motion.

* Reduced misalignment of bearing rod ends to prevent binding and premature wear due to high degrees of misalignment.

Do not disrupt the anti-rotation arm's 90° alignment with the motor shaft during mounting. A parallel orientation between the anti-rotation arm and the motor shaft is not recommended because it will significantly reduce the anti-rotation arm's performance and operational lifetime. Each rod end can withstand only 50° of deviation. Ideally, the anti-rotation arm should be mounted with rod-end ball centered in its socket.

Recommended torque: 20 FT-LBS. [27 N-m].



1 EC TYPE-EXAMINATION CERTIFICATE

2 Equipment intended for use in Potentially Explosive Atmospheres Directive 94/9/EC

3 Certificate Number: Sira 09ATEX5172X Issue: 1

4 Equipment: Optical Encoder

5 Applicant: Dynapar Corporation

6 Address: 1675 Delany Road
Gurnee
Illinois
60031-1282
USA

7 This equipment and any acceptable variation thereto is specified in the schedule to this certificate and the documents therein referred to.

8 Sira Certification Service, notified body number 0518 in accordance with Article 9 of Directive 94/9/EC of 23 March 1994, certifies that this equipment has been found to comply with the Essential Health and Safety Requirements relating to the design and construction of equipment intended for use in potentially explosive atmospheres given in Annex II to the Directive.

The examination and test results are recorded in the confidential reports listed in Section 14.2.

9 Compliance with the Essential Health and Safety Requirements, with the exception of those listed in the schedule to this certificate, has been assured by compliance with the following documents:

EN 60079-0:2006

EN 60079-11:2007

IEC 60079-0:2007 (used for guidance in respect of marking)

EN 60079-18:2004

EN 60079-7:2007

10 If the sign 'X' is placed after the certificate number, it indicates that the equipment is subject to special conditions for safe use specified in the schedule to this certificate.

11 This EC type-examination certificate relates only to the design and construction of the specified equipment. If applicable, further requirements of this Directive apply to the manufacture and supply of this equipment.

12 The marking of the equipment shall include the following:



II 2G

Ex ia mb e IIC T4 Gb

Ta = -50 °C to +100 °C

C Ellaby
Certification Officer

Project Number 20998
C. Index 13

This certificate and its schedules may only be reproduced in its entirety and without change.

Sira Certification Service

Rake Lane, Eccleston, Chester, CH4 9JN, England

Tel: +44 (0) 1244 670900
Fax: +44 (0) 1244 681330
Email: info@siracertification.com
Web: www.siracertification.com



SCHEDULE

EC TYPE-EXAMINATION CERTIFICATE

Sira 09ATEX5172X
Issue 1

13 DESCRIPTION OF EQUIPMENT

The equipment is an optical encoder that is intended to be attached to the rotating shaft of a machine. It uses an anodized aluminium enclosure that has three internal compartments. A compartment at one end of the equipment contains certified 'Ex e' terminals that are used for external connections; external cables enter this compartment via certified 'Ex e' cable glands and any unused entries are blanked by certified 'Ex e' plugs. This 'Ex e' compartment is fitted with a lid that allows access to the terminals. The compartment at the other end of the encoder contains 'Ex m' devices that include an encapsulated printed circuit board assembly. The central compartment houses an optically encoded disc, this is fitted to a shaft that emerges from the wall of the compartment. The disc is fitted with an optical reading device that is protected by intrinsic safety, 'Ex ia', however there are no intrinsically safe inputs or outputs.

An alternative version of the equipment is fitted with a permanently connected cable. This version of the equipment has no Ex 'e' terminal compartment. Entry of the cable is again via an 'Ex e' cable gland.

Supply Input:

	15 V Version	26 V Version
Rated supply voltage at supply input:	U = 15 V U _m = 250 V	U = 26 V U _m = 250V
Rated load current at each driver output:	125 mA (T _a = -50 °C to +100 °C)	10 mA (T _a = -50 °C to +100 °C) 15 mA (T _a = -50 °C to +90 °C)

Variation 1 - This variation introduced the following changes:

- i. A 26 V rated version of the equipment was introduced, consequently, the ratings in the description were updated to recognise this change.

This certificate and its schedules may only be reproduced in its entirety and without change.

Form 9400 Issue1

Page 2 of 3

Sira Certification Service

Rake Lane, Eccleston, Chester, CH4 9JN, England

Tel: +44 (0) 1244 670900
Fax: +44 (0) 1244 681330
Email: info@siracertification.com
Web: www.siracertification.com



SCHEDULE

EC TYPE-EXAMINATION CERTIFICATE

Sira 09ATEX5172X
Issue 1

14 DESCRIPTIVE DOCUMENTS

14.1 Drawings

Refer to Certificate Annexe.

14.2 Associated Sira Reports and Certificate History

Issue	Date	Report no.	Comment
0	17 September 2009	R59A16953A	The release of the prime certificate.
1	22 October 2009	R20998A	The introduction of Variation 1.

15 SPECIAL CONDITIONS FOR SAFE USE (denoted by X after the certificate number)

15.1 All cable entry holes shall be fitted with either an ATEX certified 'Ex e' cable gland or an ATEX certified 'Ex e' plug. The type of cable and the cable glands selected shall have temperature ratings of at least the maximum ambient temperature of where the equipment is installed.

15.2 The terminals shall only be fitted with wires that have cross sectional area falling within the following limitations:

Rigid: 0.14 to 2.5 mm² / 26 to 14 AWG

Flexible: 0.14 to 1.5 mm² / 26 to 16 AWG

15.3 The equipment shall be supplied from a power supply that has an output that is isolated from earth.

16 ESSENTIAL HEALTH AND SAFETY REQUIREMENTS OF ANNEX II (EHSRs)

The relevant EHSRs that are not addressed by the standards listed in this certificate have been identified and individually assessed in the reports listed in Section 14.2.

17 CONDITIONS OF CERTIFICATION

17.1 The use of this certificate is subject to the Regulations Applicable to Holders of Sira Certificates.

17.2 Holders of EC type-examination certificates are required to comply with the production control requirements defined in Article 8 of directive 94/9/EC.

17.3 All complete manufactured units shall be subjected to a routine 500 V r.m.s. a.c. between all terminals and the equipment enclosure, in accordance with Clause 10.3 of EN 60079-11:2007.

17.4 All manufactured units shall be subjected to a visual inspection on the encapsulation. No damage shall be evident such as cracks in the compound, exposure of the encapsulated parts, flaking, inadmissible shrinkage, swelling, decomposition, failure in adhesion or softening.

This certificate and its schedules may only be reproduced in its entirety and without change.

Form 9400 Issue1

Page 3 of 3

Sira Certification Service

Rake Lane, Eccleston, Chester, CH4 9JN, England

Tel: +44 (0) 1244 670900

Fax: +44 (0) 1244 681330

Email: info@siracertification.com

Web: www.siracertification.com

Certificate Annexe

Certificate Number: Sira 09ATEX5172X
Equipment: Optical Encoder
Applicant: Dynapar Corporation



Issue 0

Drawing	Sheets	Rev.	Date (Sira stamp)	Title
114507-0001	1 of 1	B	17 Sep 09	LABEL,4428,EN,ATEX
200869-0001	1 of 3	D	15 Sep 09	DWG, ASSEMBLY, EN, ATEX
200869-0002	2 of 3	D	15 Sep 09	DWG, ASSEMBLY, EN, ATEX
200869-0003	3 of 3	D	15 Sep 09	DWG, ASSEMBLY, EN, ATEX
200870-0001	1 of 1	-	15 Sep 09	DWG, ARTWORK, EN ATEX
200871-0001	1 of 1	C	15 Sep 09	DWG, SCHEMATIC, EN, ATEX
200885-0001	1 of 1	-	15 Sep 09	ATEX NON BARRIER POTTING INSTRUCTIONS
502947-0001	1 of 1	A	15 Sep 09	ASIC MODULE ASSEMBLY

Issue 1

Drawing	Sheets	Rev.	Date (Sira stamp)	Title
114507-0002	1 of 1	B	21 Oct 2009	Label, 4428, EN, ATEX
200871-0001	1 of 1	D	21 Oct 2009	Dwg, Schematic, EN, ATEX

This certificate and its schedules may only be reproduced in its entirety and without change.

Form 9400 Issue 1

Page 1 of 1

Sira Certification Service

Rake Lane, Eccleston, Chester, CH4 9JN, England

Tel: +44 (0) 1244 670900
Fax: +44 (0) 1244 681330
Email: info@siracertification.com
Web: www.siracertification.com



EC Declaration of Conformity

Dynapar Corporation declares under our sole responsibility that the products(s) listed below conform to the relevant provisions of directive 94/9/EC of 23 March 1994.

Product(s): Optical Encoder Series EN42 and EN44

Notified Body: SIRA Certification Service (0518)
Rake Lane
Eccleston
Chester
CH4 9JN

Manufacturer: Dynapar Corporation
1675 Delany Road
Gurnee, IL 60031 USA

Conformity has been demonstrated with reference to the following documentation:

EC Type - Examination Certificate SIRA 09ATEX5172X Issue: 1

Compliance with the Essential Health and Safety requirements has been re-assessed to the following standards with no changes required to the product:

- EN 60079-0: 2006
- EN 60079-7:2007
- EN 60079-11: 2007
- EN 60079-18: 2004
- EN 60079-0: 2007*

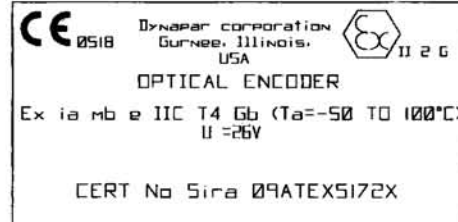
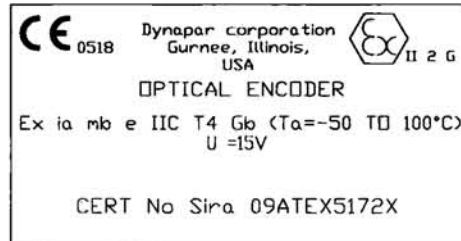

The product is also in compliance with EMC Directive 2004/108/EC and the requirements of the EN 61326 standard. * Used for guidance in respect of marking

David Hill

David Hill

11/18/09

David Hill, Operations Manager, Dynapar Corporation, 1675 Delany Road, Gurnee, Illinois 60031