

High Resolution Linear Encoders at an affordable price are now available. Encodertech brings the cost of sub-micron linear resolution within the reach of designers of reduced cost, OEM Systems. Digital outputs with resolutions of 25 Cycles per Millimeter or 720 Cycles per Inch are standard. Additionally, the new LAM250 and 500 Analog Linear Encoder Modules, at 250 and 500 Cycles per inch, offer resolutions of less than one Micron through the use of standard interpolate circuits. These Modules are used extensively in X-Y positioning systems, particularly pick-and-place equipment requiring resolutions of one Micron. The Modular Linear Encoder concept is very flexible in allowing the customer to utilize many product variations.

LINEAR OPTICAL ENCODER MODULE

For Measurement of **Linear Motion, Digital or Analog**

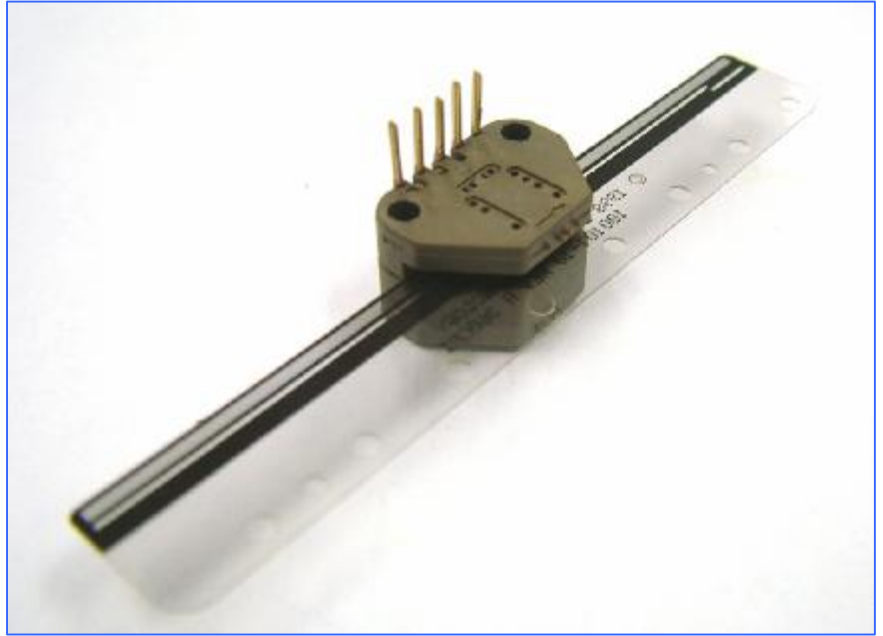

Technical Specifications

Electrical

Code Resolution	Incremental See ordering information for standard resolutions
Supply voltage	5Vdc \pm 10% at 30mA maximum
Output format	Dual channel quadrature
Output format options	Index
Output type - LM	Square wave, TTL and CMOS compatible, 10mA sink
Output type LAM	Analog output from diode array
Frequency response	125 kHz (data and index)

Mechanical

Dimensions	See module outline dimensions
Weight	<.25 ounces
Termination	.025 sq. Discrete pins
Materials	Module: Molded PPS 40% glass (R-4) Pins: gold plated Scale: mylar or etched metal

Environmental Conditions

Operating temp range	-40 to 100°C (non condensing)
Storage temp range	-40 to 100°C

Module Interface

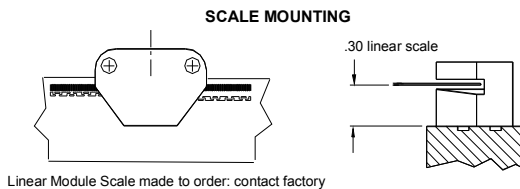

The above specifications are subject to change without notice. Dimensions shown in inches.

Ordering Information

Encoder Module

Digital LM	720CPI	-	3T
	1.		3.
Analog LAM	500CPI	-	6T
	2.		3.

Linear Scale

1. Standard Resolution - Digital

12 cycles/mm = 0.0008 Inch resolution after x4
25 cycles/mm = 0.01mm resolution after x4
720 cycles per inch = 0.00035 inch resolution after x4

2. Standard Resolution - Analog

250 cycles per inch = 1.6 microns after 16x interpolate and 4x edge multiplication.

500 cycles per inch = .8 microns after 16X interpolate and 4x edge multiplication.

3. Length & Index Positioning

Per customer requirement
Consult factory for availability, part numbers and pricing.

1. Linear Digital Module (LM)

12 cycles/mm12CPMM
25 cycles/mm25CPMM
720 cycles/inch.....720CPI
See "Current Resolutions List" for Scale Lengths.

2. Linear Analog Module (LAM)

250 cycles /inch.....250CPI
500 cycles/inch.....500CPI
See "Current Resolutions List" for Scale Lengths.

3. Lead Positions

Digital		
Side Exit	Top Exit	
A1S	A1T	
AB2S	AB2T	
ABZ3S	ABZ3T	

Analog	
Top Exit	
ABZ6T	

Encoder Technology

30 N. Alamos Drive ♦ Cottonwood, AZ 86326 ♦ Tel: 928-634-1010 ♦ Fax: 928-634-1220
Toll Free: 866-634-4040 ♦ www.encodedertech.com

Module Outline Dimensions

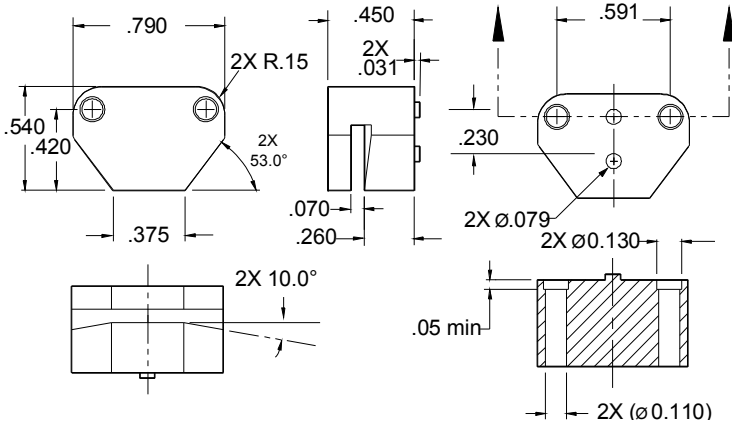

LM Output Format

OUTPUT STAGE

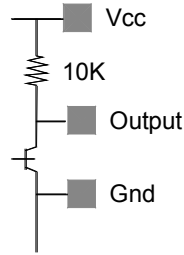

DATA AND INDEX

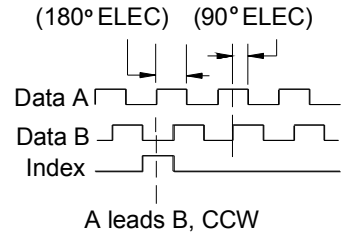

Read left to right as shown in photo.

Pin Layouts

The Optical Encoder Modules come standard in either top mount or side mount with A, B, and Index Channels.

ABZ CONFIGURATION 5X .025 square pins

SIDE MOUNT (-1S, -2S, -3S)

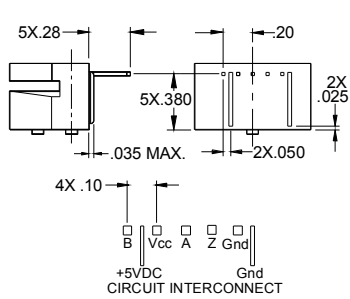

TOP MOUNT (-1T, -2T, -3T)

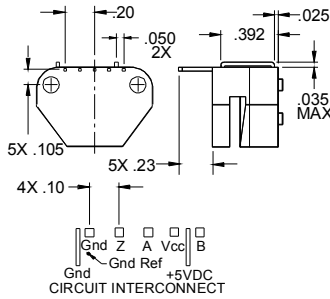

ANALOG CONFIGURATIONS (-6T) 8X .025 square pins

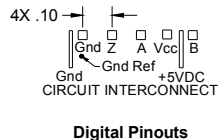
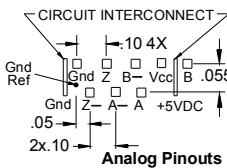
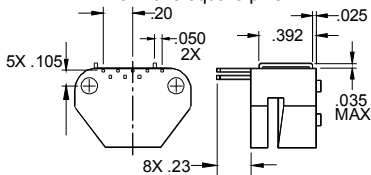

LAM Output Format

(180° ELEC) (90° ELEC)

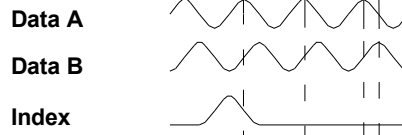

Output signal shown after analog signal processing

Recommended Mounting Configurations

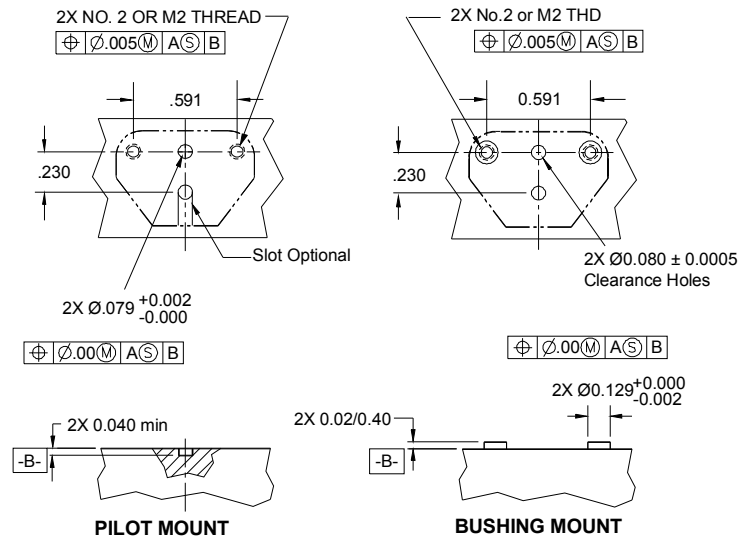

Encoder Technology

30 N. Alamos Drive ♦ Cottonwood, AZ 86326 ♦ Tel: 928-634-1010 ♦ Fax: 928-634-1220
Toll Free: 866-634-4040 ♦ www.encodedtech.com